

SONY[®]

HD CAMCORDER

HDW-F900

HDCAM



MAINTENANCE MANUAL Part 1

1st Edition

Serial No. 10001 and Higher

⚠ 警告

このマニュアルは、サービス専用です。
お客様が、このマニュアルに記載された設置や保守、点検、修理などを行うと感電や火災、人身事故につながる可能性があります。
危険をさけるため、サービストレーニングを受けた技術者のみご使用ください。

⚠ WARNING

This manual is intended for qualified service personnel only.
To reduce the risk of electric shock, fire or injury, do not perform any servicing other than that contained in the operating instructions unless you are qualified to do so. Refer all servicing to qualified service personnel.

⚠ WARNUNG

Die Anleitung ist nur für qualifiziertes Fachpersonal bestimmt.
Alle Wartungsarbeiten dürfen nur von qualifiziertem Fachpersonal ausgeführt werden. Um die Gefahr eines elektrischen Schlages, Feuergefahr und Verletzungen zu vermeiden, sind bei Wartungsarbeiten strikt die Angaben in der Anleitung zu befolgen. Andere als die angegeben Wartungsarbeiten dürfen nur von Personen ausgeführt werden, die eine spezielle Befähigung dazu besitzen.

⚠ AVERTISSEMENT

Ce manuel est destiné uniquement aux personnes compétentes en charge de l'entretien. Afin de réduire les risques de décharge électrique, d'incendie ou de blessure n'effectuer que les réparations indiquées dans le mode d'emploi à moins d'être qualifié pour en effectuer d'autres. Pour toute réparation faire appel à une personne compétente uniquement.

X-RAY RADIATION WARNING

Be sure that parts replacement in the high voltage block and adjustments made to the high voltage circuits are carried out precisely in accordance with the procedures given in this manual.

CAUTION

Danger of explosion if battery is incorrectly replaced.

Replace only with the same or equivalent type recommended by the manufacturer.
Dispose of used batteries according to the manufacturer's instructions.

Vorsicht!

Explosionsgefahr bei unsachgemäßem Austausch der Batterie.

Ersatz nur durch denselben oder einen vom Hersteller empfohlenen ähnlichen Typ.
Entsorgung gebrauchter Batterien nach Angaben des Herstellers.

ATTENTION

Il y a danger d'explosion s'il y a remplacement incorrect de la batterie.

Remplacer uniquement avec une batterie du même type ou d'un type équivalent recommandé par le constructeur.
Mettre au rebut les batteries usagées conformément aux instructions du fabricant.

ADVARSEL!

Lithiumbatteri-Eksplosionsfare ved fejlagtig håndtering.
Udskiftning må kun ske med batteri af samme fabrikat og type.
Levér det brugte batteri tilbage til leverandøren.

Voor de klanten in Nederland

Dit apparaat bevat een MnO₂-Li batterij voor memory back-up.

Raadpleeg uw leverancier over de verwijdering van de batterij op het moment dat u het apparaat bij einde levensduur afdankt.

Gooi de batterij niet weg, maar lever hem in als KCA.

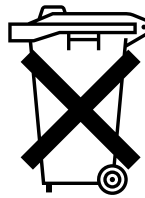

Bij dit produkt zijn batterijen geleverd. Wanneer deze leeg zijn, moet u ze niet weggooien maar inleveren als KCA.

Für Kunden in Deutschland

Entsorgungshinweis: Bitte werfen Sie nur entladene Batterien in die Sammelboxen beim Handel oder den Kommunen. Entladen sind Batterien in der Regel dann, wenn das Gerät abschaltet und signalisiert "Batterie leer" oder nach längerer Gebrauchsdauer der Batterien "nicht mehr einwandfrei funktioniert". Um sicherzugehen, kleben Sie die Batteriepole z.B. mit einem Klebestreifen ab oder geben Sie die Batterien einzeln in einen Plastikbeutel.

Table of Contents

Manual Structure

Purpose of this manual	5
Related manuals	5
Contents	6
Trademarks	6

1. Installation

1-1. Supplied Accessories	1-1
1-2. Operating Conditions	1-1
1-3. Connectors	1-1
1-4. Input/Output Signals	1-2

2. Service Overview

2-1. How to clean the head when the head is clogged	2-1
2-2. Main Parts Location and Circuit Configuration	2-2
2-2-1. PC Board Location	2-2
2-2-2. Location of Main Mechanical Parts	2-5
2-2-3. Location/Functions of Sensors	2-6
2-3. Settings of Board Switches and Short-circuit Pins	2-8
2-3-1. IF-819 Board	2-8
2-3-2. SY-285 Board	2-8
2-3-3. SV-218 Board	2-9
2-3-4. RPR-13 Board	2-9
2-3-5. APR-55 Board	2-10
2-3-6. HN-243 Board	2-12
2-3-7. RP-113 Board	2-12
2-4. Removal and Installation of Exterior Parts	2-13
2-5. Plug-in Board Removal and Installation	2-14
2-5-1. AD-167 Board	2-14
2-5-2. DPR-152 Board	2-14
2-5-3. DA-148 Board	2-15
2-5-4. IF-819, SV-218, SY-285 Boards	2-16
2-5-5. General Information of Plug-in Board Removal and Installation	2-16
2-6. Cassette Compartment Assembly Removal and Installation	2-18
2-7. Cassette Tape Manual Ejection	2-20
2-8. Fixtures and Measuring Equipment for Adjustment	2-21
2-8-1. Fixtures	2-21
2-8-2. Measuring Equipment	2-23

3. Error Code and Error Message

3-1. Error Code	3-1
3-2. Error Message	3-2
3-3. DIAGNOSTIC Mode	3-3

4. Setup Menu

4-1. Setup Menu	4-1
4-2. TOP Menu	4-3
4-3. OPERATION Menu	4-4
4-4. PAINT Menu	4-11
4-5. MAINTENANCE Menu	4-20
4-6. FILE Menu	4-26
4-7. DIAGNOSIS Menu	4-30

5. File System

5-1. File Structure	5-1
5-2. Operator File	5-2
5-3. Preset Operator File	5-3
5-4. Registering the Scene File	5-4
5-5. Registering Reference Files	5-5
5-6. Registering the Lens File	5-8
5-7. Registering the OHB File	5-9
5-7-1. Storing the Black Shading and White Shading	5-9
5-7-2. Adjusting the ND Offset	5-10
5-8. File items	5-11

6. Periodic Maintenance and Inspection

6-1.	Cleaning	6-1
6-1-1.	General Information on Cleaning	6-1
6-1-2.	Cleaning of Tape Running Surface of Upper Drum and Video Heads	6-3
6-1-3.	Cleaning of Tape Running Surface of Lower Drum and Lead Surface	6-4
6-1-4.	Cleaning of Stationary Heads	6-5
6-1-5.	Cleaning of Tape Path System and Tape Cleaner	6-6
6-1-6.	Cleaning of Filter	6-7
6-2.	Maintenance After Use in Special Environments	6-8
6-3.	Periodic Inspections	6-9
6-3-1.	Hours Meter	6-9
6-3-2.	Periodic Inspection List	6-10
6-3-3.	Recommended Replacing Parts	6-12

7. Overall Block Diagrams

7-1.	Camera Block	7-1
7-2.	VTR Block	7-4

Manual Structure

Purpose of this manual

This manual is the maintenance manual part 1 of HDCAM camcorder HDW-F900. This manual is intended for use by trained system and service engineers, and is provided information required for the installation, maintenance information and information for primary service.

Related manuals

Besides this maintenance manual part 1, the following manuals are available.

- **HDW-F900 Operation Manual (Supplied with this unit)**

This manual is necessary for the use and the operation of this unit.

Part No. : 3-203-941-XX

- **HDW-F900 Maintenance Manual Part 2 Volume 1, Volume 2 (Available on your request)**

This manual is provided information that is premised the parts level service (adjustments, board layouts, schematic diagrams, detailed parts lists and the like.) for this unit.

If this manual is required, please contact to your local Sony Sales Office/Service Center.

Volume 1 (Service Information , Replacement of Parts and Adjustments)

Part No. : 9-968-563-XX

Volume 2 (Schematic Diagrams, Board Layouts, Block Diagrams, Exploded Views and Parts Lists).

Part No. : 9-968-564-XX

- **HDVF-20A Operation Manual (Supplied with HDVF-20A)**

This manual is necessary for the use and the operation of HDVF-20A.

Part No. : 3-203-934-XX

- **HDVF-20A Maintenance Manual (Available on your request)**

This manual is provided information that is premised the parts level service (adjustments, board layouts, schematic diagrams, detailed parts lists and the like.) for HDVF-20A.

If this manual is required, please contact to your local Sony Sales Office/Service Center.

Part No. : 9-968-559-XX

Contents

The maintenance manual part 1 is organized by following sections.

Section 1 Installation

This section is described about the information that is required to install (operating conditions, connection information and the like.) and when installing this unit.

Section 2 Service Overview

This section is described about fundamental information that is required for service (removing of cabinet and cassette compartment, location of printed circuit boards and main parts, fixture and measuring equipments, and the like.), measures against trouble.

Section 3 Error Code and Error Message

This section is described about DIAGNOSTIC mode, error messages and error code.

Section 4 Setup Menu

This section is described about the setup menu.

Section 5 File System

This section is described about the file system to control data.

Section 6 Periodic Maintenance and Inspection

This section is described about the recommended periodic maintenance and the cleaning procedures.

Section 7 Overall Block Diagrams

This section is described about overall block diagrams.

Section 1

Installation

1-1. Supplied Accessories

Accessories	Sony Part No.	Qt'y
Microphone	1-542-295-11	1
Spacer, Microphone	3-179-882-01	1
Holder (B), Microphone	3-680-582-01	1
Eye, Cup (S)	3-682-494-02	1
Cover, Rain	3-725-262-03	1
Belt Assy, Shoulder	A-6772-374-C	1
Cushion, Eye Cup Assy	X-3678-187-1	1
Operation Manual	—	1
Maintenance Manual Part 1	—	1

1-2. Operating Conditions

Operating temperature : 0 °C to 40 °C

Storage temperature : -20 °C to +60 °C

Humidity : No condensation allowed

Locations to avoid :

- Extremely hot or cold places
- Very humid places
- Places with strong vibrations
- Places with strong electric or magnetic fields
- Places exposed to direct sunlight for a long time or near heaters

1-3. Connectors

When connecting cables to the connectors during installation or maintenance work, use the following connectors or cables.

Connector name	Connection connectors/Cables
GENLOCK IN (RETURN)	
TC IN	1-560-069-11
TC OUT	BNC Coaxial Connector
MONITOR OUT Y	Plug
MONITOR OUT Pb	
MONITOR OUT Pr	
AUDIO IN CH1/CH2	1-508-084-00 XLR 3-pin, Male
AUDIO OUT	1-508-370-00 XLR 5-pin, Female
MIC IN +48 V	1-508-084-00 XLR 3-pin, Male
DC IN	1-508-362-00 XLR 4-pin, Female
DC OUT 12 V	1-566-425-11 Round Type 4-pin, Male
REMOTE	1-766-848-11 Round Type 8-pin, Male

1-4. Input/Output Signals

Input

GENLOCK IN (RETURN) : 1.0 V p-p, 75 Ω
 TC IN : 0.5 V to 18 V p-p, 10 k Ω
 MIC IN +48 V : -60 dBu
 AUDIO IN CH-1, CH-2 : -60 dBu/+4 dBu
 (0 dBu = 0.775 Vrms)
 DC IN : DC 11 to 17 V

DC IN : XLR, 4-pin (Male)

<External View>

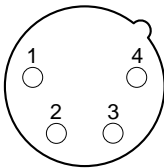

Pin No.	Signal Designation
1	GND
2	—
3	—
4	BATT OUT (+)

Output

MONITOR OUT : 1.0 V p-p, 75 Ω , unbalanced
 TC OUT : 1.0 V p-p, 75 Ω
 EARPHONE : 8 Ω , $-\infty$ to -18 dBu variable
 AUDIO OUT : 0 dBm (600 Ω terminatd)
 DC OUT 12 V : DC 11 to 17 V

DC OUT 12V : DIN, 4-pin(Female)

<External View>

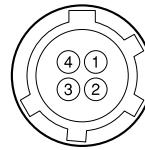

Pin No.	Signal Designation
1	UNREG GND
2	—
3	—
4	UNREG +12 V

BATT IN : 5-pin (Male)

<External View>

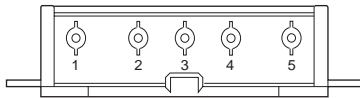

Pin No.	Signal Designation
1	BATT IN (-)
2	BATT ID
3	BATT REM
4	LIGHT CONT
5	BATT IN (+)

LENS : 12-pin (Female)

<External View>

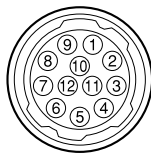

Pin No.	Signal Designation
1	RET (SW)
2	VTR TRIG
3	LENS GND
4	AUTO +5 V IN
5	IRIS CONT
6	UNREG +12 V
7	IRIS PSTN
8	REMOTE/LOCAL
9	EXTENDER
10	ZOOM PSTN
11	FOCUS PSTN
12	PROJ ON

VF : 20-pin (Female)

<External View>

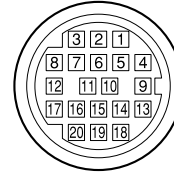

Pin No.	Signal Designation
1	SDA VF IN/OUT
2	—
3	—
4	SCL VF OUT
5	COLOR/BW IN
6	—
7	—
8	G TALLY
9	VF PEAKING CTL OUT
10	—
11	—
12	VF VIDEO (Y) OUT
13	VF VIDEO GND
14	VF VIDEO (Pb) OUT
15	VF VIDEO (Pr) OUT
16	—
17	R TALLY (UP)
18	—
19	VF GND
20	UNREG +12 V

REMOTE : 8-pin (Female)

<External View>

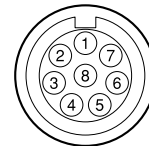

Pin No.	Signal Designation
1	TX RCP DATA (X)
2	TX RCP DATA (Y)
3	RX RCP DATA (X)
4	RX RCP DATA (Y)
5	TX GND
6	UNREG +12 V
7	UNREG (GND)
8	Y
	CHASSIS GND

Section 2

Service Overview

2-1. How to clean the head when the head is clogged

When the head is Clogged, refer to Section 6, Periodic Maintenance and Inspection for appropriate head-cleaning.

2-2. Main Parts Location and Circuit Configuration

2-2-1. PC Board Location

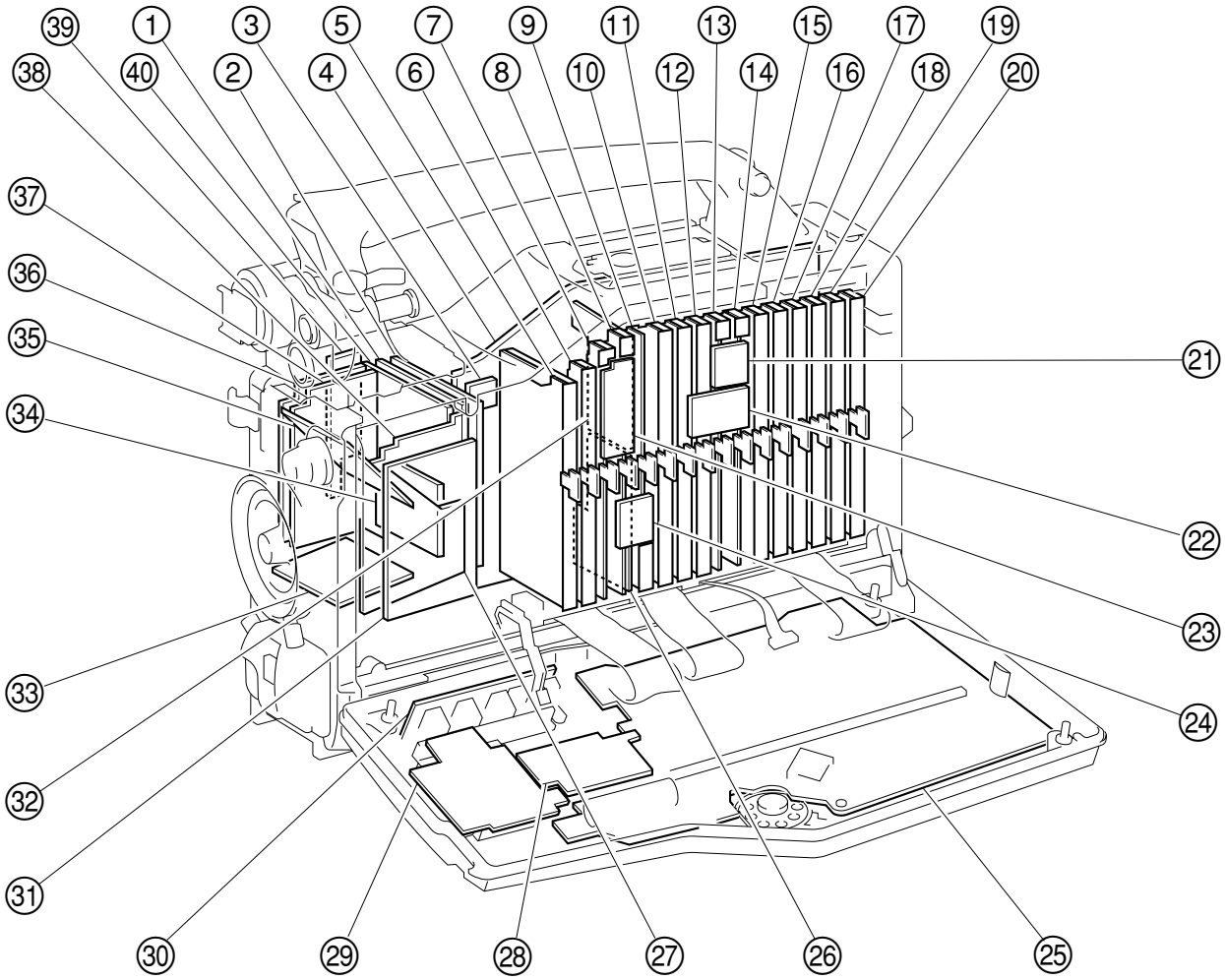

System Configuration	Board Name	Circuit Function	No.
CCD unit	BI-145 (B)	CCD block	③⑤
	BI-145 (G)	CCD block	③④
	BI-145 (R)	CCD block	③③
	CN-1432	CCD block	③
	CN-1946	CCD block	②⑦
	DR-411	CCD driver, Timing generator	③⑧
	DU-19	Connector Board	③⑨
	NR-68	CCD block	③⑦
	PA-238	Pre-amp	③⑥
	RP-113	CCD block	①
	SH-74	Shading correction signal generator	②
	TG-213	Timing generator	④⑩
Camera	AD-167	Flare, PRE knee, White clip, Black clip, PRE filter, A/D converter	⑦
	CN-1614	Filter	③①
	CN-1940	Relay board for AD-167 board and DPR-152 board	②③
	CN-2085	Relay board for DPR-152 board and DA-148 board	②④
	DA-148	Post filter, D/A converter	⑨
	DPR-152	SCVP (Digital processing), VFS (Frame rate converter)	⑧
	DPR-157	Digital processing	③②
	IF-819	System controller, Fan controller	⑫
	RE-145F	Power supply, Regulator (CCD block)	⑤
	RPR-13	Assistant board for VFS	②⑥
	SG-267	GEN lock, Timing pulse generator (CTG), Character generator	⑪
	VA-195	Video amp, White gain, White shading compensator	⑥
	VDA-51	Monitor out, VF out, Character mix, Marker mix, Zebra mix, Skin marker mix	⑩
	Video	DEC-95	ECC/BRR decoder
EN-143		BRR encoder (B), Timing generator	⑮
ENC-59		BRR encoder (A), ECC encoder	⑮
EQ-89		RF equalizer	⑲
VN-12		Concealment, FIL (Rate convert)	⑰
Servo	SV-218	Servo controller	⑬
System control	SY-285	System controller for VTR block, Timecode controller	⑭
Time code, Audio	APR-55	Audio processor	⑲
Others	CN-2043	Connector board for Memory Stick	⑲
	CN-2044	Relay board for IF-819 board and SY-285 board	⑲
	CN-2078	Relay board for SV-218 board and SY-285 board	⑲
	CP-361	Control panel	⑳
	MB-877	Mother board	④
	VR-175	Memory card, Audio select switch, Alarm level, Monitor level	⑲

2-2. Main Parts Location and Circuit Configuration

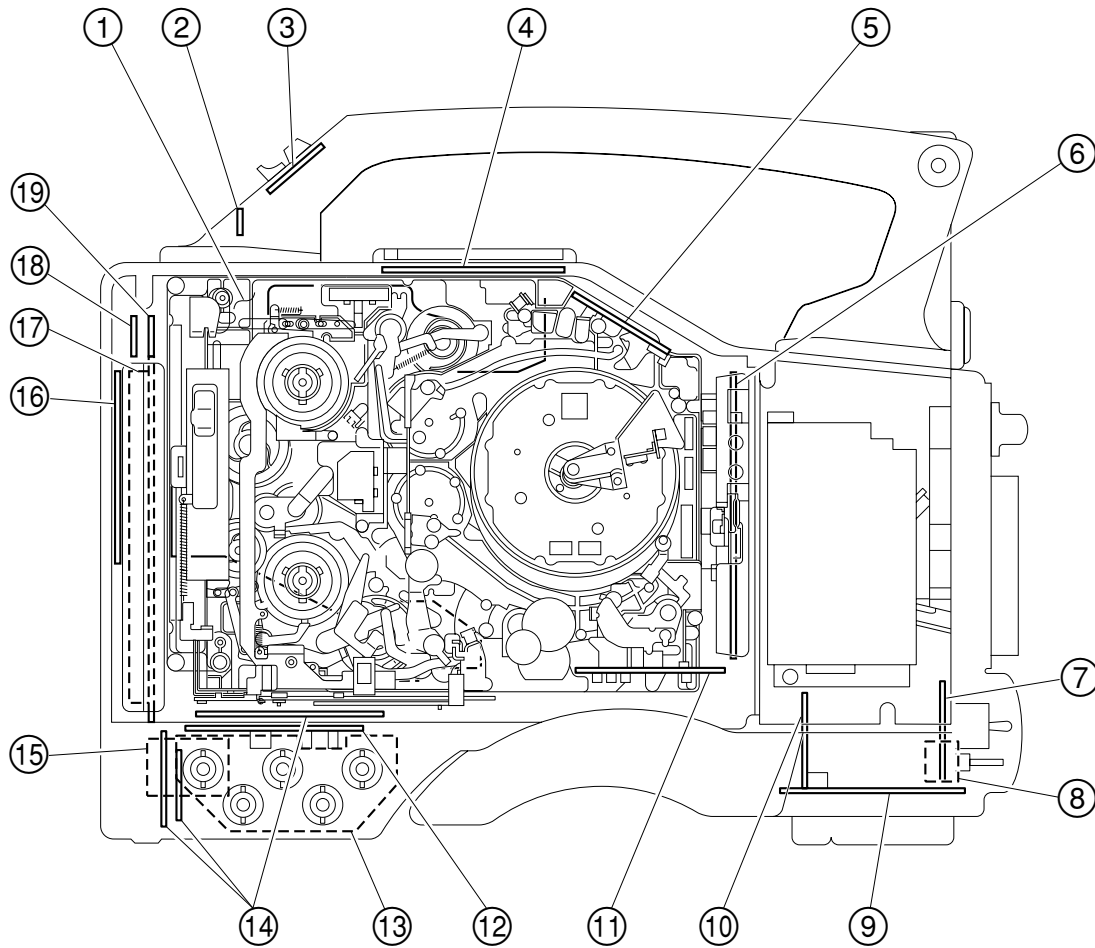

System Configuration	Board Name	Circuit Function	No.
Head	CTL-10	CTL head amp	⑤
	CUE-2	CUE head amp	⑪
	HN-243	Harness, Erase head amp, TC head amp	⑥
Mic	CN-1642	Connector board for Camera mic	⑩
	MA-92	Camera mic amp	⑨
	SW-911	VTR S/S switch, Shutter switch, ABB/AWB switch	⑦
	SW-912	Rotary encoder switch	⑧
Connector box	CN-2025	Connector board for Audio IN/OUT & EXT DC IN/OUT	⑭
	CN-2046	Connector board for Monitor OUT, EXT TC IN/OUT	⑬
	CO-38	Connector (Genlock IN, Remote)	⑮
	PS-483	Power supply, Circuit breaker	⑫
Power supply	RE-139	Power supply, Regulator (VTR)	⑰
	RE-140	Power supply, Regulator (VTR)	⑱
Rear panel	CN-2024	Adaptor	⑯
Others	HP-90	Headphone	②
	KY-293	Function key	④
	SE-275	Tape sensor, DEW sensor	①
	SW-1032	Back tally, Back tally switch	③
	CCM-33B	Reader/writer	⑱

2-2-2. Location of Main Mechanical Parts

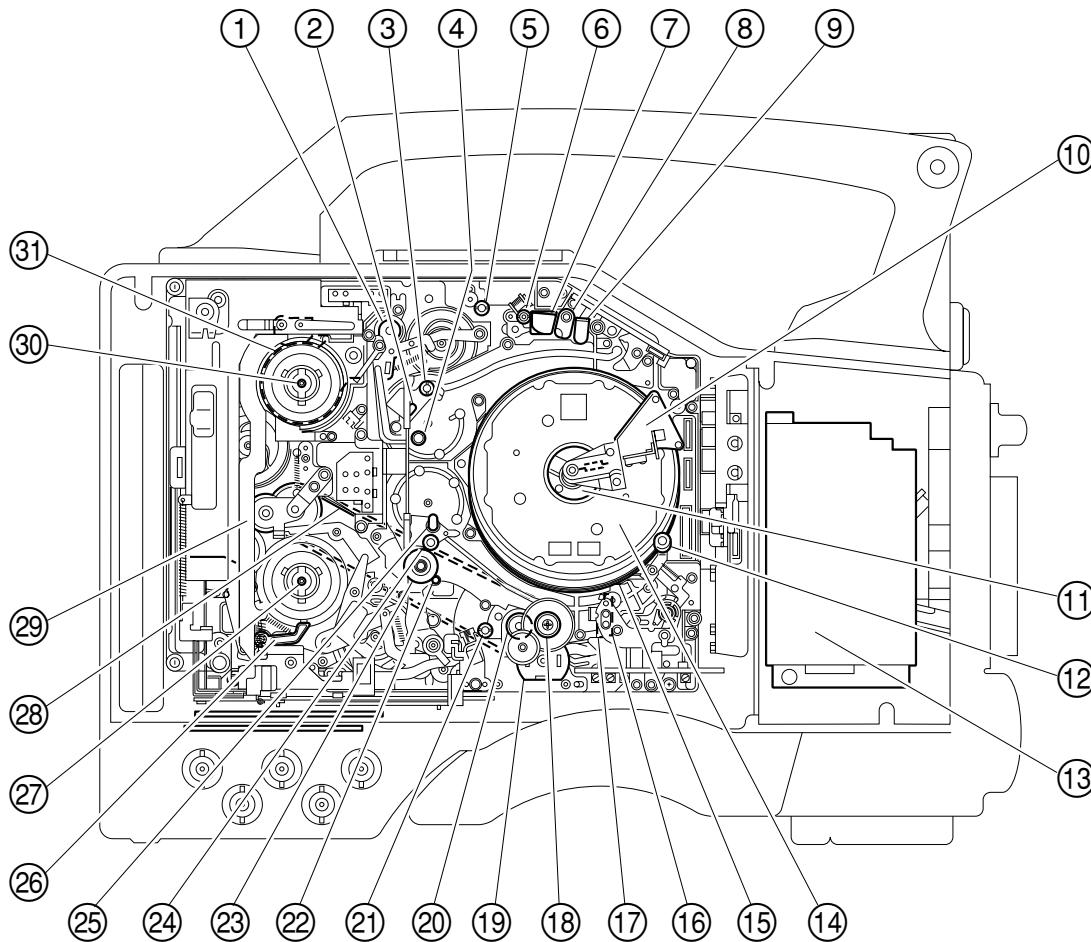

- | | |
|---|---------------------------------|
| ① Tension regulator arm | ①⑦ CUE/TC head |
| ② S1 tape guide (on S slider) | ①⑧ Manual eject knob |
| ③ S2 tape guide (on S slider) | ①⑨ Threading motor |
| ④ Tension regulator guide (S4 tape guide) | ①⑩ Capstan motor |
| ⑤ S5 tape guide | ①⑪ T3 tape guide |
| ⑥ S3 tape guide | ①⑫ T drawer guide |
| ⑦ Full erase head | ①⑬ Pinch roller |
| ⑧ Tape cleaner | ①⑭ T2 tape guide (on T slider) |
| ⑨ CTL head | ①⑮ T1 tape giude (on T slider) |
| ⑩ Brush | ①⑯ T soft brake |
| ⑪ Slip ring | ①⑰ T reel table |
| ⑫ Video head cleaner | ①⑱ Timing belt |
| ⑬ CCD block | ①⑲ Gear |
| ⑭ Upper drum | ①⑳ S reel table |
| ⑮ Lower drum | ①㉑ Brake band |
| ⑯ CUE head cleaner | |

2-2-3. Location/Functions of Sensors

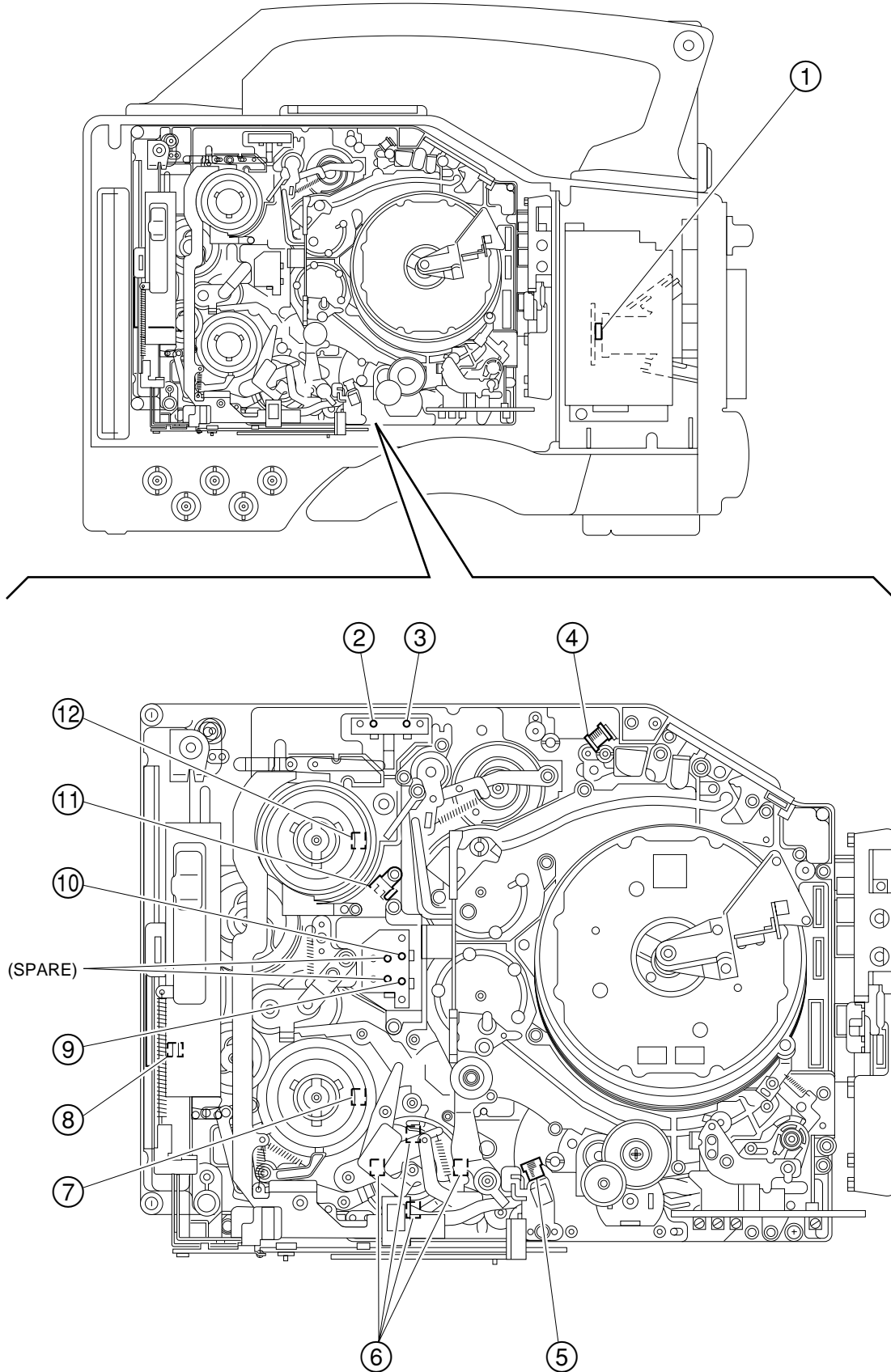

① Temperature Sensor

This sensor detects the temperature to perform black correction.

② Cassette-in sensor

This sensor detects whether a cassette is in.

③ REC INHIBIT sensor

This sensor detects the REC inhibiting plug of the cassette tape.

④ Tape end sensor

This sensor detects the end of the tape running in the forward direction.

⑤ Tape top sensor

This sensor detects the end of the tape running in the REW direction.

⑥ Function cam sensor

This sensor detects the rotation position of a cam.

⑦ Take-up reel table rotation sensor

This sensor detects the rotation of the take-up reel table. The FG output signal of this sensor is fed to a servo circuit so as to calculate the winding diameter of the tape.

⑧ Cassette lock sensor (switch)

This sensor detects whether the cassette compartment is locked.

⑨ Tape thickness sensor

Using a tub on the back side of the cassette tape, this sensor detects the thickness of the tape wound on a cassette tape that is being inserted into the unit.

⑩ Reel hub diameter sensor

The reel hub diameter of a cassette tape varies depending on the length of the tape wound on the cassette tape. The reel hub diameter sensor detects the reel hub diameter by the tab on the back side of the cassette tape. The output signal of this sensor is fed to a servo circuit so as to calculate the winding diameter of the tape.

⑪ Condensation sensor

This sensor detects whether condensation occurs in the unit.

⑫ Supply reel table rotating sensor

This sensor detects the rotation of the supply reel table. The FG output signal of this sensor is fed to a servo circuit so as to calculate the winding diameter of the tape.

2-3. Settings of Board Switches and Short-circuit Pins

2-3-1. IF-819 Board

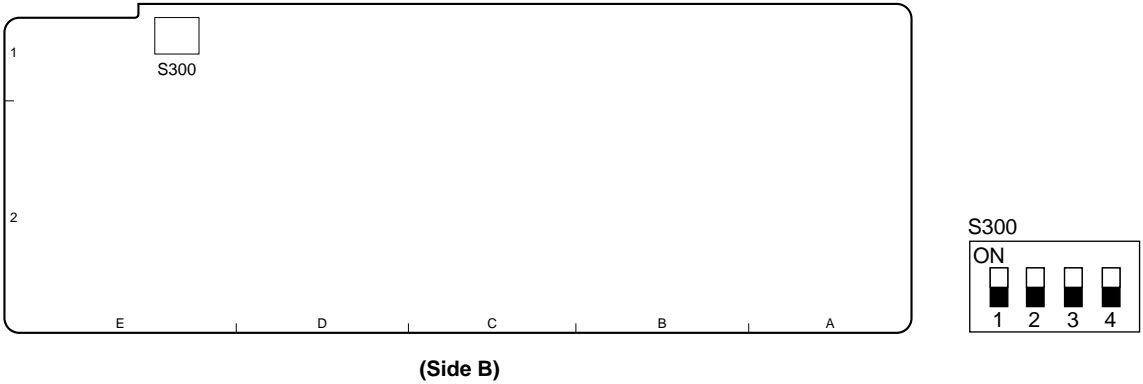

IF-819 Board Switch

Switch No.	Designation	Description	Factory setting
S300 1 to 4	SETUP MENU Select	Setup menu to be displayed on the viewfinder can be selected. (See the table below)	OFF

Switch Settings

S300-1	S300-2	S300-3	S300-4
OFF	OFF	OFF	OFF
ON	OFF	OFF	OFF
OFF	ON	OFF	OFF
ON	ON	OFF	OFF
OFF	OFF	ON	OFF

Setup Menu

OPERATION	PAINT	MAINTENANCE	FILE	DIAGNOSIS
Yes	Yes	Yes	Yes	Yes
Yes	Yes	Yes	No	Yes
Yes	Yes	No	No	Yes
Yes	No	No	No	Yes
Yes	No	No	No	No

2-3-2. SY-285 Board

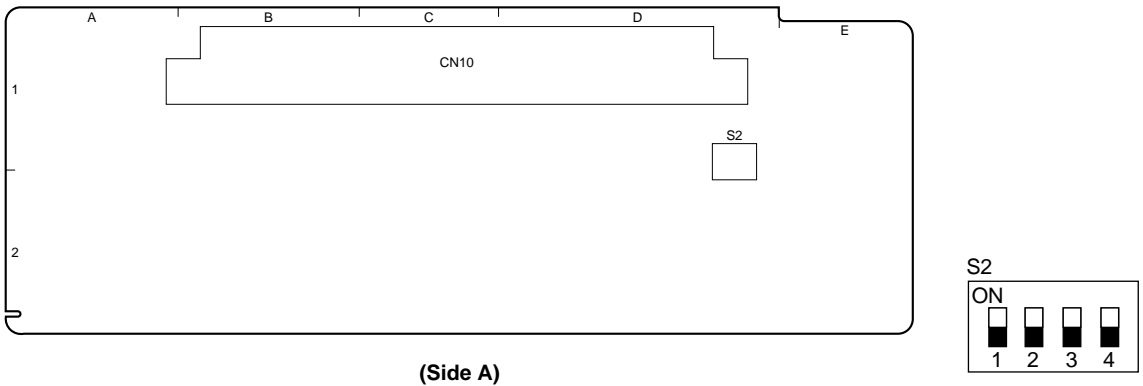

SY-285 Board Switch

Switch No.	Description	Factory setting
S2 1 to 4	Factory use	OFF

2-3-3. SV-218 Board

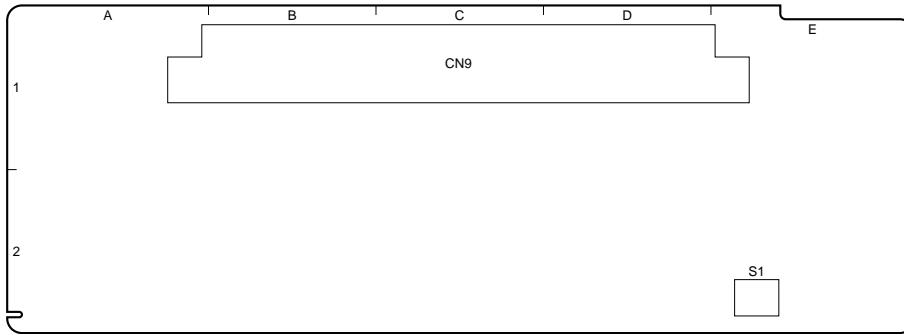

(Side A)

SV-218 Board Switch

Switch No.	Description	Factory setting
S1 1to 4	Factory use	OFF

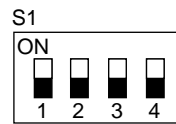

2-3-4. RPR-13 Board

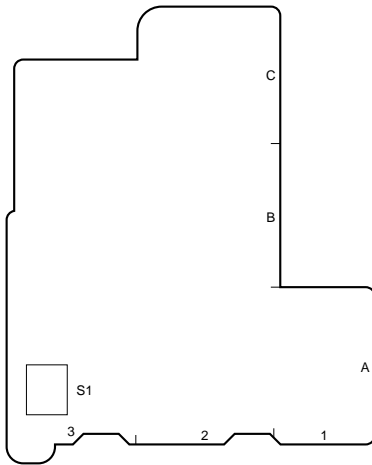

(Side A)

RPR-13 Board Switch

Switch No.	Description	Factory setting
S1 1to 4	Factory use	OFF

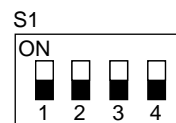

2-3-5. APR-55 Board

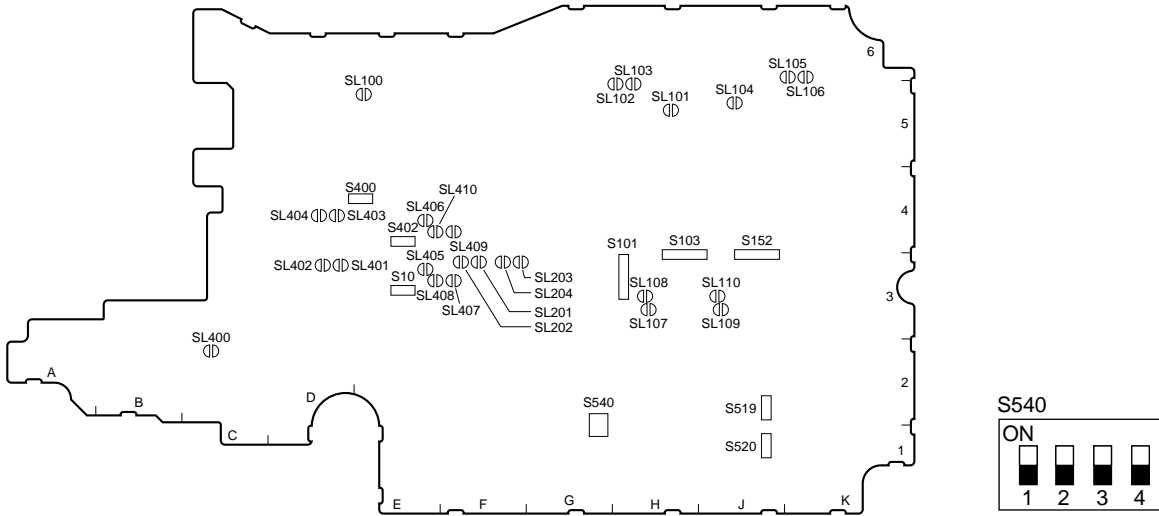

(Side B)

Switches on APR-55 Board

Switch No.	Designation	Description	Factory setting
S10	CH-1 OUTPUT LIM ON-OFF	CH-1 Selects whether to turn on or off the output limiter. ON : Audio output LIMITER ON OFF : Audio output LIMITER OFF	ON
S402	CH-2 OUTPUT LIM ON-OFF	CH-2 Selects whether to turn on or off the output limiter. ON : Audio output LIMITER ON OFF : Audio output LIMITER OFF	ON
S101	CH-1 FRONT MIC VR ON-OFF	Selects whether to adjust the REAR CH-1 audio input signal level by the FRONT MIC VR. ON : Adjust OFF : Not adjust	OFF
S103	CH-1 LIM ON-OFF	Selects whether to turn on or off the limiter in the CH-1 audio input stage. ON : CH1 Audio INPUT LIMITER ON OFF : CH1 Audio INPUT LIMITER OFF	OFF
S152	CH-2 LIM ON-OFF	Selects whether to turn on or off the limiter in the CH-2 audio input stage. ON : CH2 Audio INPUT LIMITER ON OFF : CH2 Audio INPUT LIMITER OFF	OFF
S400	CUE ON-OFF	Selects whether to feed the CUE signal or D/A signal to the audio output terminal in the PB mode. ON : Feed the CUE signal OFF : Feed the D/A signal	OFF
S519	EXT-LK UBIT INT-EXT	Selects whether to lock the user bit externally. INT : Not lock externally EXT : Lock externally	INT
S520	REAL TIME VITC-LTC	Select which user bit REAL TIME is recorded onto. VITC : U-BIT of VITC LTC : U-BIT of LTC	VITC
S540 1	AUDIO SG MONITOR ON-OFF	Selects whether to feed the 1 KHz test signal to MONITOR OUT when the signal is selected. ON : Feed OFF : Not feed	OFF
2 to 4	—	Factory use	OFF

Slit Lands on APR-55 Board

Ref. No.	Name	Input level			
		(+4 dBu)	0 dBu	-1 dBu	-3 dBu
SL101	CH-1 AUDIO INPUT	OPEN	OPEN	OPEN	SHORT
SL102	LEVEL Select	OPEN	SHORT	OPEN	OPEN
SL103		OPEN	OPEN	SHORT	OPEN
SL104	CH-2 AUDIO INPUT	OPEN	OPEN	OPEN	SHORT
SL105	LEVEL Select	OPEN	SHORT	OPEN	OPEN
SL106		OPEN	OPEN	SHORT	OPEN

() : Factory setting

Ref. No.	Name	Headroom level		
		(20 dB)	18 dB	16 dB
SL107	REC CH-1 HEADROOM	OPEN	SHORT	OPEN
SL108	LEVEL Select	OPEN	OPEN	SHORT
SL109	REC CH-2 HEADROOM	OPEN	SHORT	OPEN
SL110	LEVEL Select	OPEN	OPEN	SHORT
SL201	REC CH-3 HEADROOM	OPEN	SHORT	OPEN
SL202	LEVEL Select	OPEN	OPEN	SHORT
SL203	REC CH-4 HEADROOM	OPEN	SHORT	OPEN
SL204	LEVEL Select	OPEN	OPEN	SHORT
SL401	PB CH-1 HEADROOM	OPEN	SHORT	OPEN
SL402	LEVEL Select	OPEN	OPEN	SHORT
SL403	PB CH-2 HEADROOM	OPEN	SHORT	OPEN
SL404	LEVEL Select	OPEN	OPEN	SHORT

() : Factory setting

Ref. No.	Name	Output level		
		+4 dBm	(0 dBm)	-3 dBm
SL405	CH-1 AUDIO OUTPUT	OPEN	OPEN	SHORT
SL407	LEVEL Select	SHORT	OPEN	OPEN
SL408		SHORT	OPEN	OPEN
SL406	CH-2 AUDIO OUTPUT	OPEN	OPEN	SHORT
SL409	LEVEL Select	SHORT	OPEN	OPEN
SL410		SHORT	OPEN	OPEN

() : Factory setting

Ref. No.	Name	Factory use
SL100	-	OPEN
SL400	-	SHORT

2-3-6. HN-243 Board

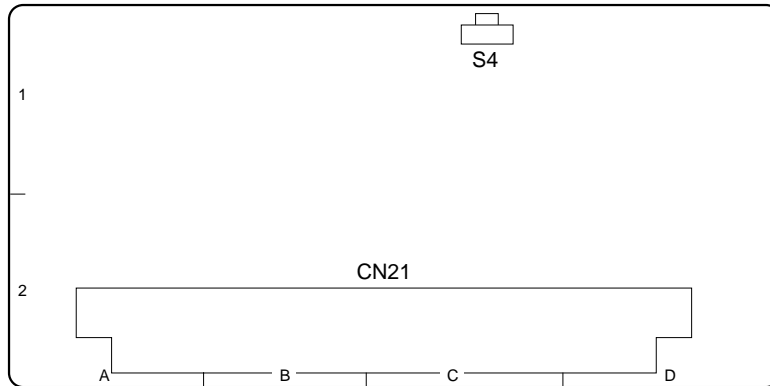

(Side A)

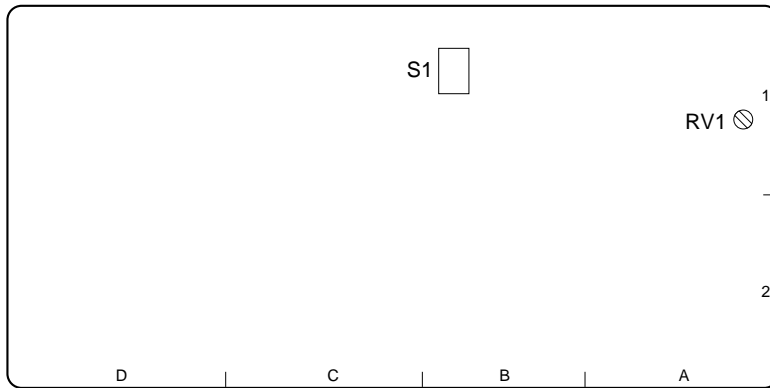

(Side B)

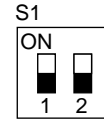

Switches on HN-243 Board

Switch No.	Designation	Description	Factory setting
S1	1	ADJ Turns on or off the adjustment mode. ON : The adjustment mode ON OFF : The adjustment mode OFF	OFF
	2	TRK Turns on or off the tracking control. ON : The tracking control volume (RV1) ON OFF : The tracking control volume (RV1) OFF	OFF
S4	REC head PB selector switch	Selects the normal REC or REC head PB. REC : Normal REC TEST : REC head PB	REC

2-3-7. RP-113 Board

All the switches on the RP-113 board are “Factory use”. Never change the settings.
(Factory setting : OFF)

2-4. Removal and Installation of Exterior Parts

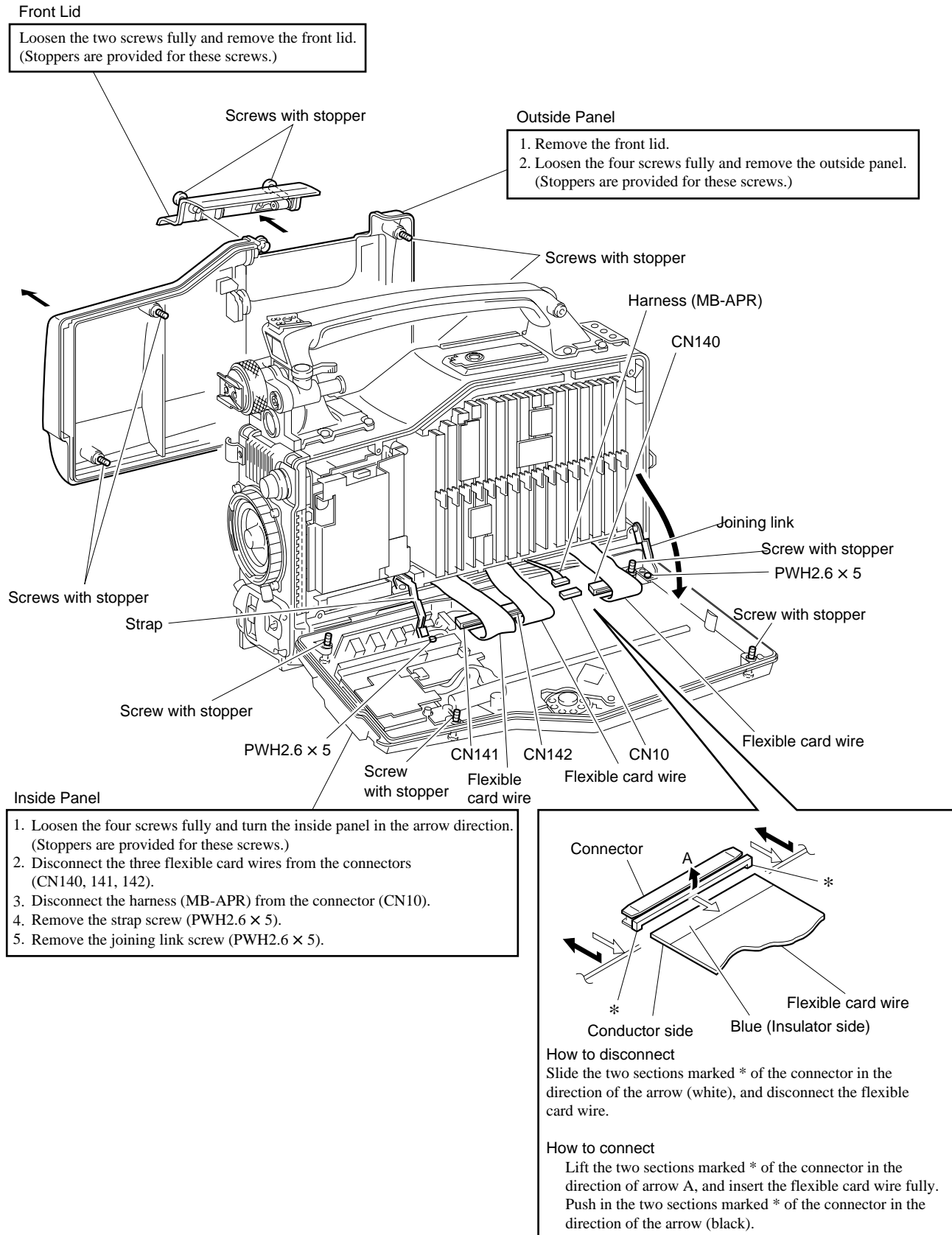

2-5. Plug-in Board Removal and Installation

2-5-1. AD-167 Board

Note

When drawing out the AD-167 board, refer to Section 2-5-5 “General Information of Plug-in Board Removal and Installation”.

1. Draw out the CN-1940 board in the arrow direction.

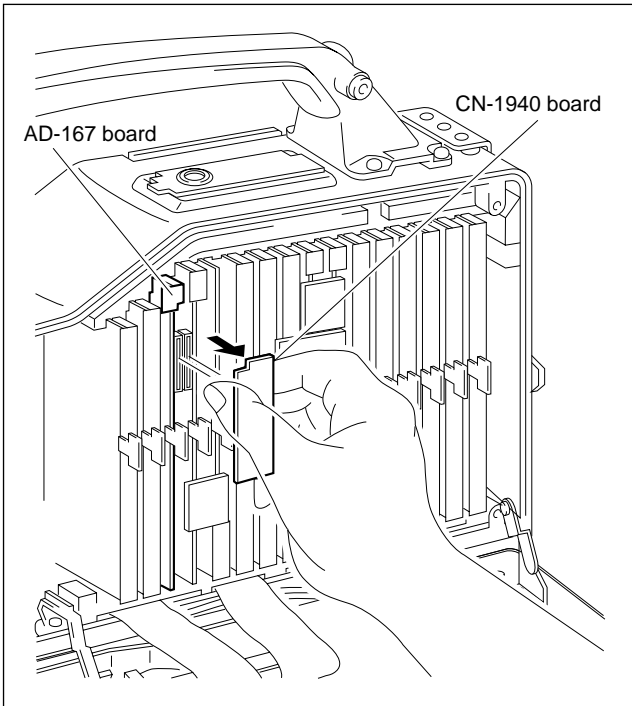

2. Draw out the AD-167 board.

Note for installation

- When installing AD-167 board, refer to Section 2-5-5 “General Information of Plug-in Board Removal and Installation”.
- When installing the CN-1940 board, align the connector position and insert it carefully and securely.

2-5-2. DPR-152 Board

Note

When drawing out the DPR-152 board, refer to Section 2-5-5 “General Information of Plug-in Board Removal and Installation”.

1. Draw out the CN-1940 and CN-2085 boards in the arrow direction.

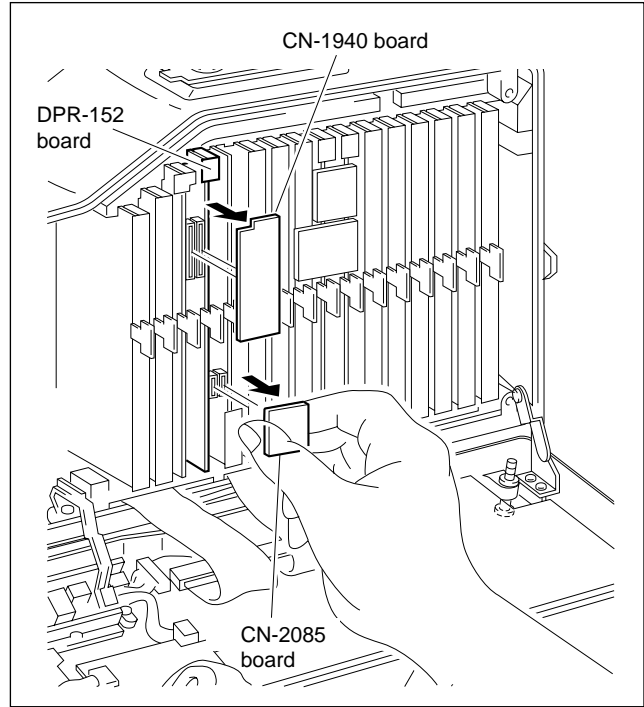

2. Release the clamper retaining the heat pipe unit in the arrow direction.
3. Draw carefully out the DPR-152 board.

Note

As the heat pipe unit is thrust out together with the board, use care when drawing.

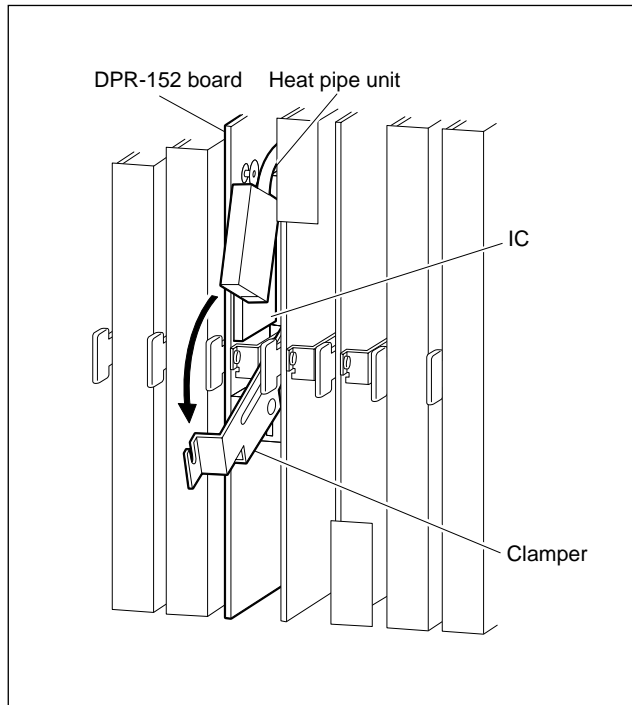

Note for installing

- When installing the DPR-152 board, with the heat pipe lifted up, insert the DPR-152 board.
- When installing the DPR-152 board, refer to Section 2-5-5 “General Information of Plug-in Board Removal and Installation”.
- When installing the CN-1940 and CN-2085 boards, align the connector position and insert them carefully and securely.

2-5-3. DA-148 Board

Note

When drawing out the DA-148 board, refer to Section 2-5-5 “General Information of Plug-in Board Removal and Installation”.

1. Draw out the CN-2085 board in the arrow direction.
(Refer to Section 2-5-2.)
2. Draw out the DA-148 board.

Note for installation

- When installing the DA-148 board, refer to Section 2-5-5 “General Information of Plug-in Board Removal and Installation”.
- When installing the CN-2085 board, align the connector position and insert it carefully and securely.

2-5-4. IF-819, SV-218, SY-285 Boards

Note

When drawing out the plug-in boards, refer to Section 2-5-5 “General Information of Plug-in Board Removal and Installation”.

1. Draw out the CN-2044 and CN-2078 boards in the arrow direction.

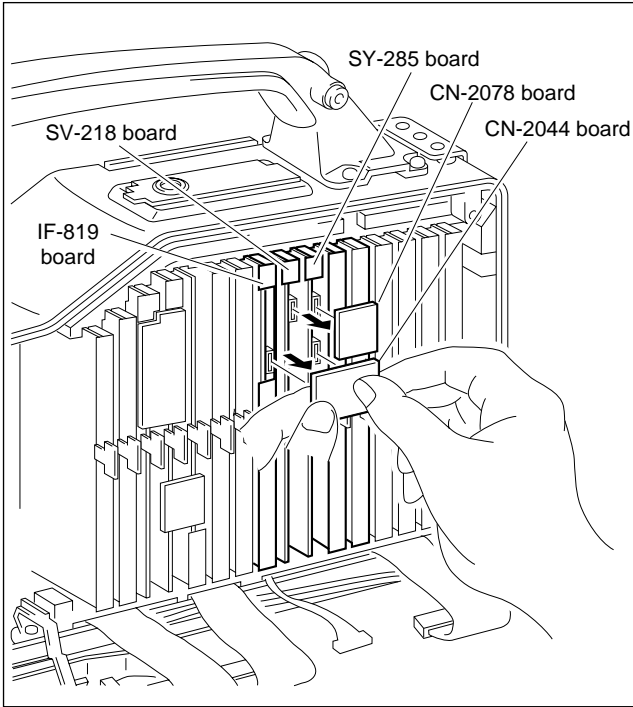

2. Draw out the IF-819, SV-218 and SY-285 boards.

Note for installing

- When installing the plug-in boards, refer to Section 2-5-5 “General Information of Plug-in Board Removal and Installation”.
- When installing the CN-2044 and CN-2078 boards, align the connector position and insert them carefully and securely.

2-5-5. General Information of Plug-in Board Removal and Installation

Removal with the Tool

Board removing tool (Sony Part No. : J-6309-350-A)

1. Insert the board removing tool in the hole on the panel at the top of the board, move the tool in the direction of the arrow, and disconnect the connector connected to the mother board.

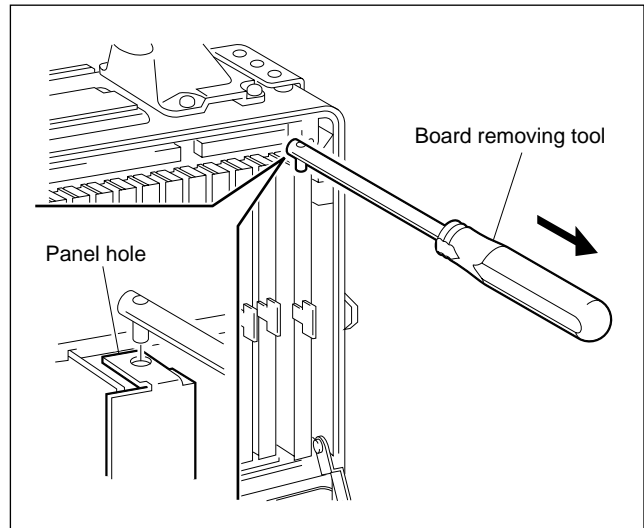

2. Remove the board from the unit by holding the pull ring in front of the board.

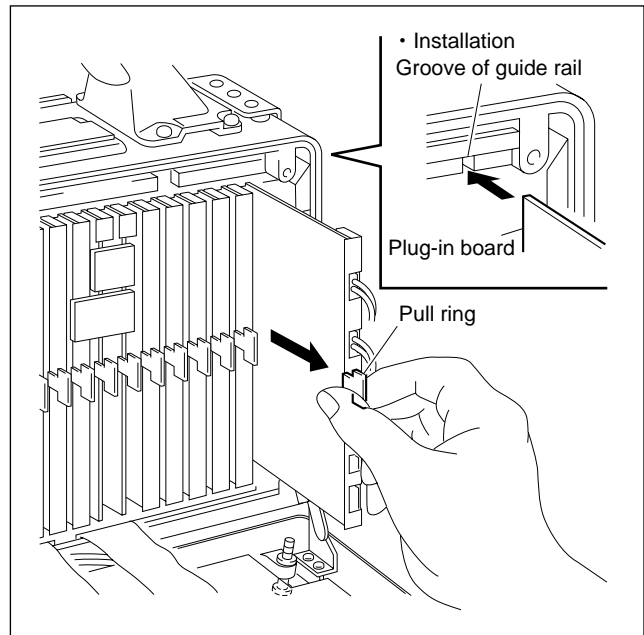

Removal Without the Tool

1. Insert a screwdriver having a small tip into the panel hole on the top of the board, move the tool in the direction of the arrow, and disconnect the connector connected to the mother board.

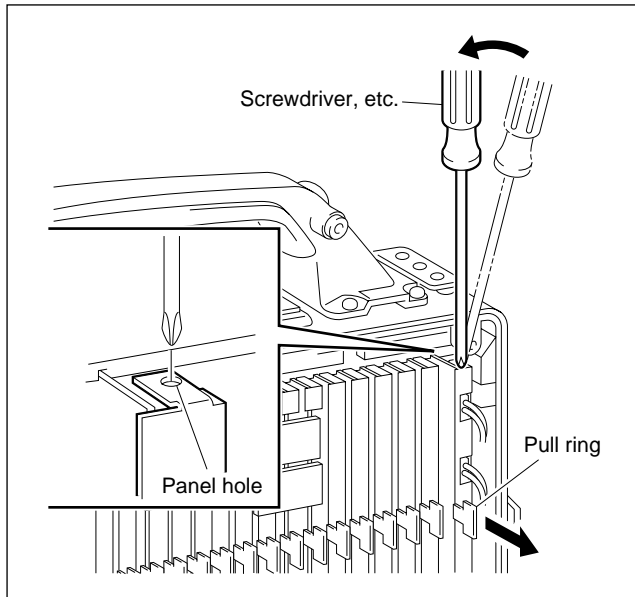

2. Holding the pull ring in front of the board, remove the board from the unit

Installation

1. Insert the board according to the board guide rails at the top and bottom of the unit.
2. Hold the top and bottom of the board firmly, and insert the board connector into the mother board.

2-6. Cassette Compartment Assembly Removal and Installation

Note

After turning off the power, perform removal and installation of the cassette compartment assembly following the procedures below.

Reference

The cassette compartment can be removed both in raised and lowered status.

Removal

1. Remove the front lid and the outside panel.
(Refer to Section 2-4.)

Note

Even a slight bend causes a short life of the flexible board, therefore use extreme care to handle it.

2. Disconnect the antenna flexible board FL-260 from the CCM-33B board of DC-DC converter and remove it.
(Refer to Section 2-7.)
3. Remove the three screws and hold the portion of the cassette compartment shown in the figure, then remove the cassette compartment in the arrow direction.

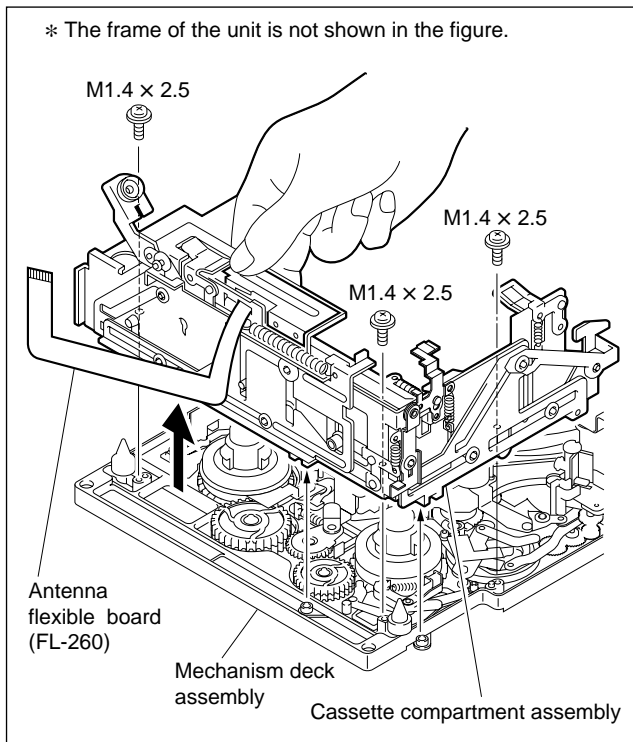

Installation

Note

Before installing a new cassette compartment, remove then reattach the two antenna sheets (magnetic sheet) and reattach the antenna flexible board FL-260.

1. Remove the two screws from a side plate assembly of a new cassette compartment to remove the stopper plate.

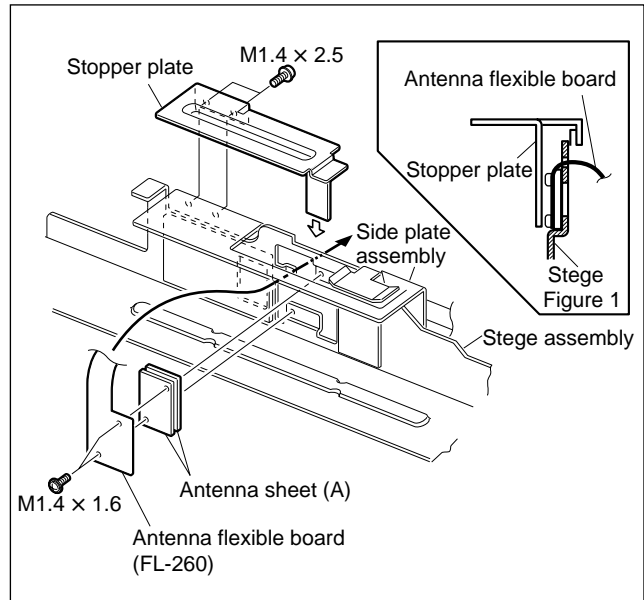

2. Route the antenna flexible board FL-260 (M1.4 x 1.6) as shown in the figure and combine the antenna flexible board with the two antenna sheets (A), then attach them to the stage assembly. (Refer to Figure 1.)
3. Install the stopper plate with the two screws.

- Adjust the position of the joint arm to have a clearance of 0.5mm between the perimeter of white roller of the joint arm and the edge of the mechanism deck assembly.

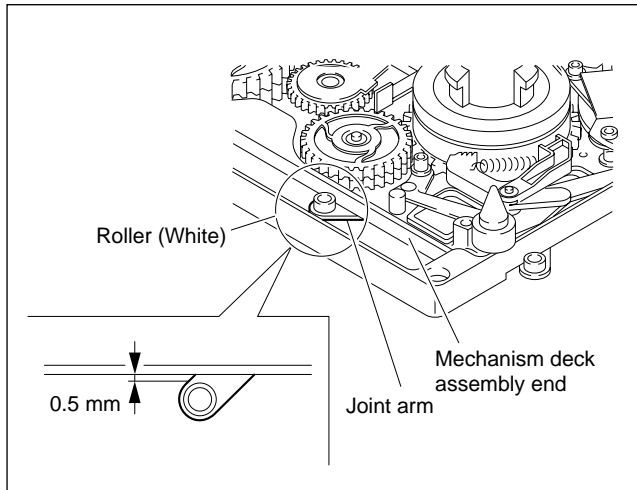

- Raise the white lock roller of the cassette compartment in the arrow direction to set it to the raised status.

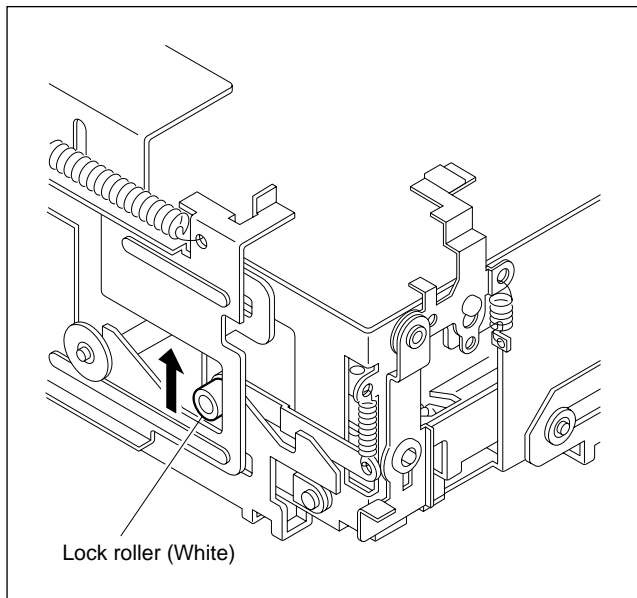

- Move the cam plate (A) on the right side of the cassette compartment in the arrow direction by manual as far as it will go.

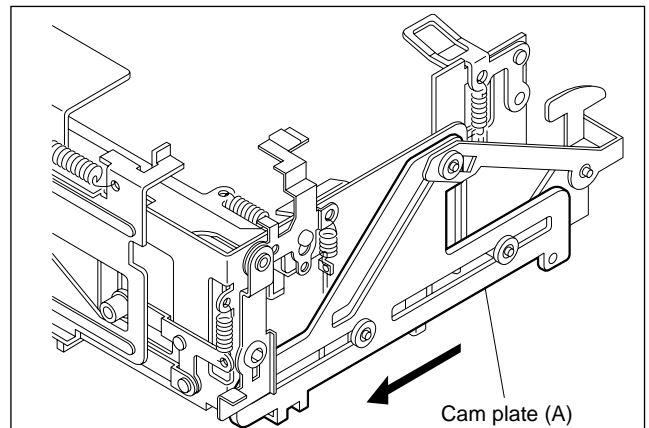

- Hold the portion of the cassette compartment shown in the figure, and attach the cassette compartment in the chassis so that the two cassette guide pins enter into the round holes of the stage. Next, check that the white roller of the eject arm which position is adjusted at step 4 fits with the notch of the cam plate (A) on the right side plate.
- Push the lever of the cassette compartment and make sure that the stage moves up and down smoothly. If not, check again from step 4.
- Attach the cassette compartment with the three screws.

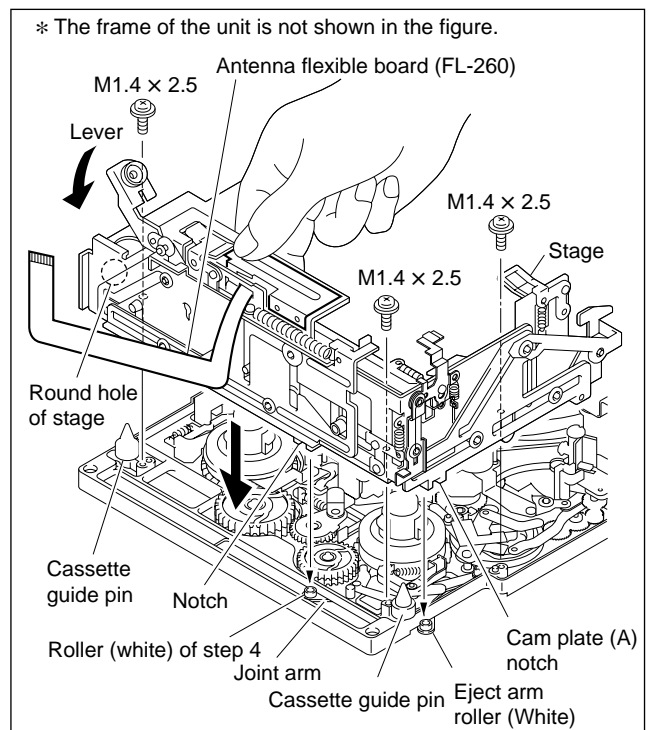

- Reconnect the antenna flexible board FL-260 to the CCM-33B board of the DC-DC converter. (Refer to Section 2-7.)

2-7. Cassette Tape Manual Ejection

1. Turn off the power switch.
2. Open the cover of the outside panel shown in the figure.
3. While pushing the gear inside using a Phillips screwdriver, turn the gear counterclockwise until the front lid lock gets released.
4. The front lid opens and the cassette tape can be ejected.

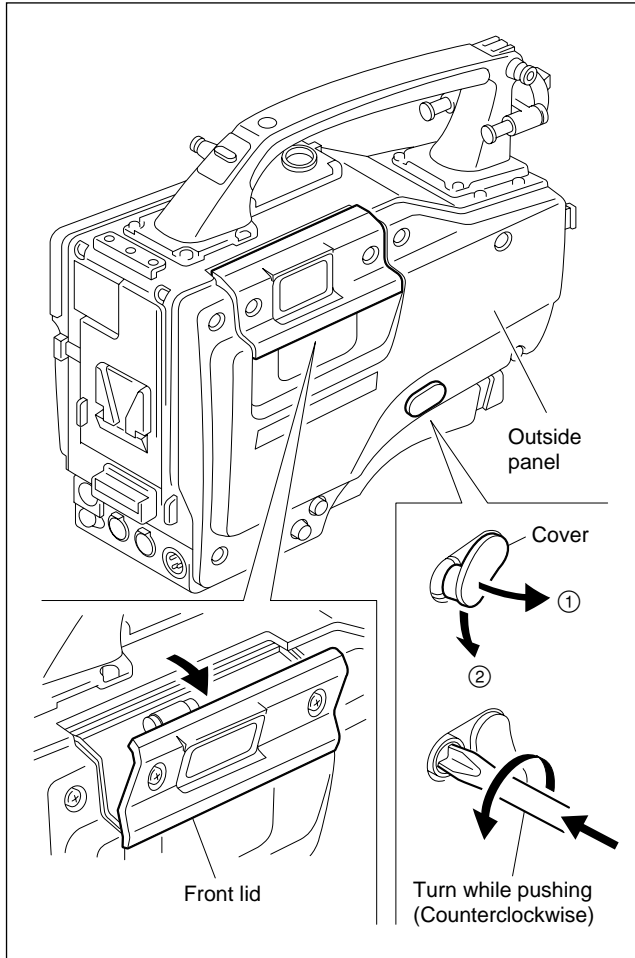

Note

Do not turn the gear after the front lid lock was released.

Closing the front lid

The front lid cannot be closed and locked in the above status.

Perform either step below to close and lock the front lid.

- (1) Turn on the power switch.
- (2) Turn the gear slightly clockwise.

If the left mentioned operations are disabled, perform the following procedures.

1. Remove the front lid and outside panel.
(Refer to Section 2-4.)
Note
Even a slight bend causes a short life of the flexible board, therefore use extreme care to handle it.
2. Disconnect the antenna flexible board from the connector of the CCM-33B board.
3. Extract the antenna flexible board from the gap between the shield case and the shield plate. (Refer to Figure 1.)
4. Remove the DC-DC converter in the arrow direction.

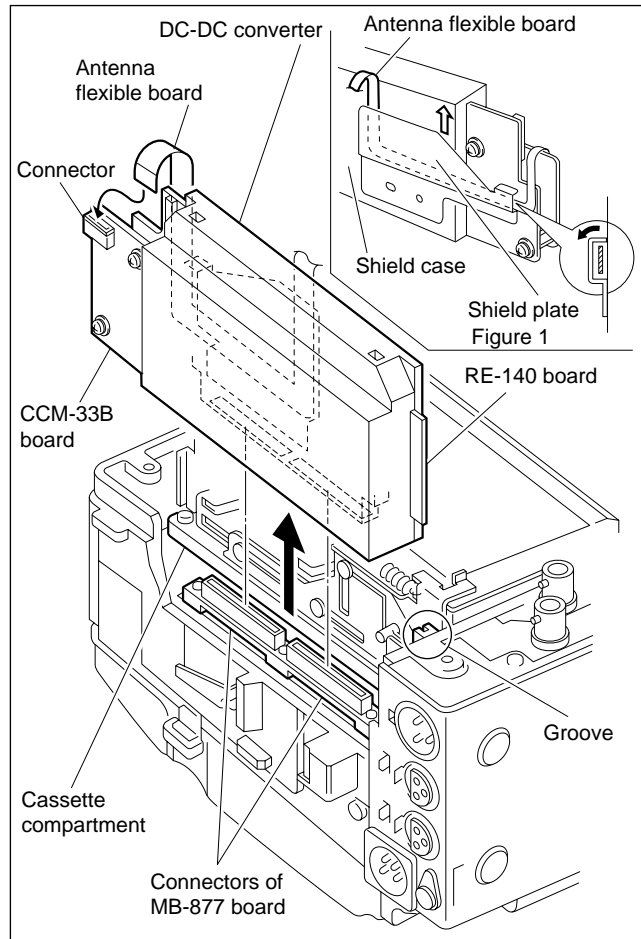

5. With the lid of the cassette tape raised, raise the white lock roller of the cassette compartment to set it to the raised status. (For details of how to raise the cassette compartment, refer to Section 2-6.)
6. Remove the cassette tape carefully preventing damage.

Note







When installing the DC-DC converter, use care about its position and direction, and insert the RE-140 board along the groove of the chassis.

2-8. Fixtures and Measuring Equipment for Adjustment

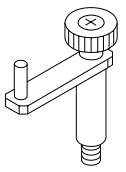
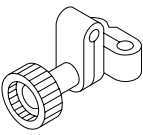
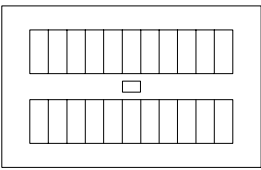
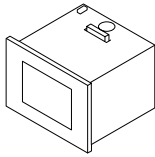
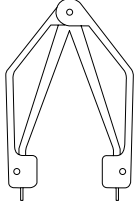
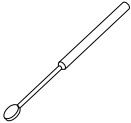
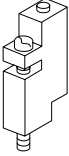
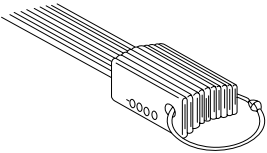
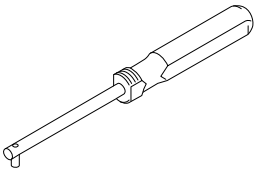
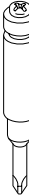
2-8-1. Fixtures

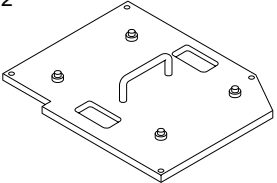
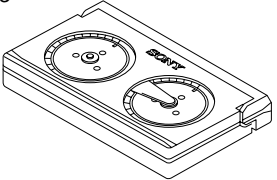
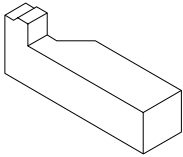
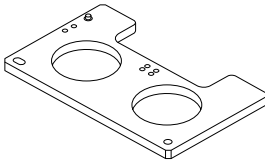
Fig. No.	Part No.	Description	Purpose
1	J-6001-820-A	Drum eccentricity gauge (3)	To adjust upper drum eccentricity
2	J-6001-830-A	Drum eccentricity gauge (2)	
3	J-6394-080-A	Gray scale chart	To adjust camera gamma
4	J-6029-140-A	Pattern box PTB-500	To adjust camera
5	J-6035-070-A	IC extraction tool	To remove PLCC IC
6	J-6080-840-A	Mirror (Small round shape)	To adjust video tracking
7	J-6087-000-A	Drum eccentricity gauge (5)	To adjust upper drum eccentricity
8	J-6152-450-A	Wire clearance check gauge	To check clearance
9	J-6309-350-A	Board extraction tool	To remove card board
10	J-6322-420-A	Tape guide adjustment screwdriver	To adjust tape path
	J-6322-420-3	Bit (0.89 across)	
11	J-6323-530-A	Stop washer insertion tool	To attach stop-washer
12	J-6323-750-A	MB dummy tool	To replace frame
13	J-6323-890-A	FWD back tension measuring cassette	To adjust FWD back tension
14	J-6324-150-A	Reel table height gauge	To adjust reel table height
15	J-6324-170-A	Cassette reference plate (1)	
16	J-6325-110-A	Torque screwdriver bit (M1.4)	To tighten screw
	J-6325-380-A	Torque screwdriver bit (M2)	
17	J-6326-120-A	Hexagonal bit (d = 1.5 mm)	
18	J-6325-400-A	Torque screwdriver (3 kg)	
19	J-6325-530-A	Upper drum eccentricity adjustment tool (6)	To adjust upper drum eccentricity
20	J-6480-040-A	Tool, side panel dummy	To replace CCD block
21	J-6420-260-A	Extension board EX-410	To check/adjust card board
22	J-6420-900-A	MB conversion board	To check HN board operations
23	J-6420-930-A	Mechanism deck extension harness Pin 100	To adjust mechanism deck
24	3-184-527-01	Cleaning cloth	To clean
25	7-661-018-18	Oil (NT-68)	To lubricate
26	7-651-000-11	Sony grease (SGL-801)	
27	7-700-736-05	Hexagon wrench (d = 1.5 mm)	To remove screw
	7-700-736-06	Hexagon wrench (d = 0.89 mm)	
28	8-960-076-01	Alignment tape HR5-1A	To adjust audio/video
	8-960-076-11	Alignment tape HR2-1A	To adjust video tracking
29	9-919-573-01	Head cleaning liquid	To Clean
30	J-6510-120-A	RS-232C interface cable	To upgrade software version
31	J-6510-150-A	RF envelope tool	To adjust RF error rate
32	7-432-950-03	TSE392-W	To attach card door assembly and camera sw cabinet
–	–	Memory stick (commercially available)	To save the camera settings

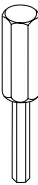
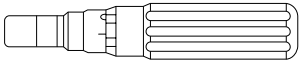
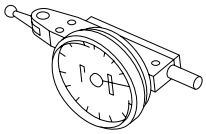
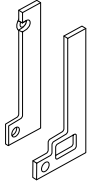
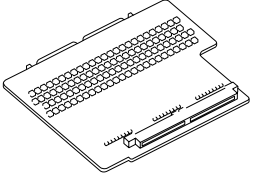
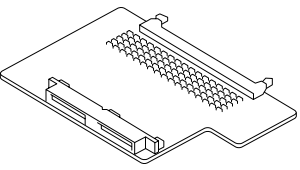
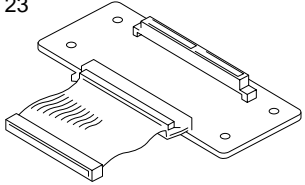
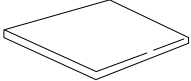
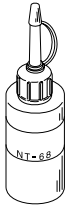
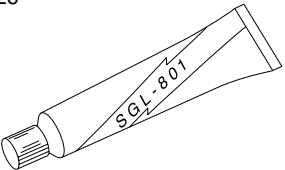
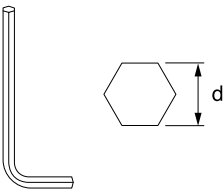
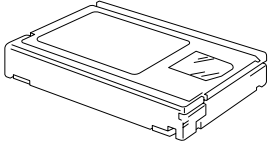
2-8. Fixtures and Measuring Equipment for Adjustment

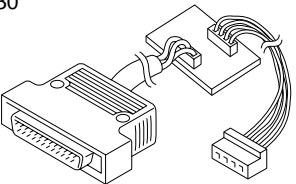
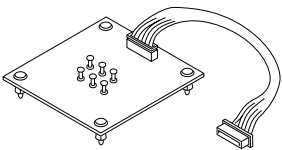
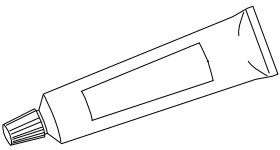
1 	2 	3 	4 	
5 	6 	7 	8 	
9 	10 	11 	12 	
13 	14 	15 	16 	17 
18 	19 	20 	21 	
22 	23 	24 	25 	
26 	27 	28 	29 	
30 	31 	32 		

2-8-2. Measuring Equipment

Use of the measuring equipment listed below or equivalent is recommended.

All the measuring equipment listed is available commercially.

Equipment	Model Name	Remarks
AC adaptor or battely	SONY AC-550	
Oscilloscope	TEKTRONIX 2465B	
HDTV Analog Waveform Monitor	TEKTRONIX 1735HD/1730HD	
HDTV Digital Waveform Monitor	LEADER LV5150D TEKTRONIX WFM1125	
Audio Analyzer	TEKTRONIX AA501A (OP.02)	for measuring distortion and levels
Audio Level Meter	HEWLETT PACKARD HP3400A	
Low Frequency Oscillator	HEWLETT PACKARD HP8904	
Frequency Counter	ADVANTEST TR5821AK	
Digital Voltmeter	ADVANTEST TR6845	
Black and White Monitor (Horizontal resolution more than 900) HD SDI-capable Monitor	SONY BVM-D20F1J/D14H5J	

Section 3 Error Code and Error Message

3-1. Error Code

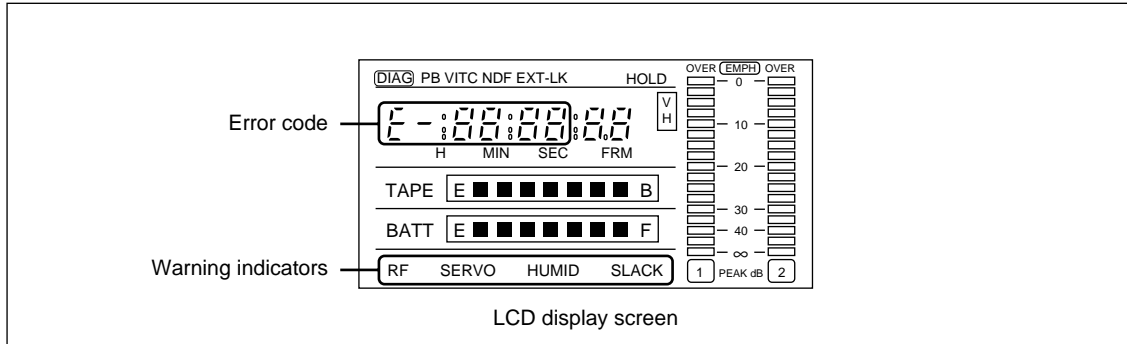

WARNING INDICATORS

The warning indicators on the LCD display screen light when a fault occurs during the power-on-sequence or normal operation.

RF : Lights when the video heads are clogged.

SERVO : Lights when the servo is out of control.

HUMID : Lights when condensation occurs on the head drum

SLACK : Lights when the tape is not wound properly or other problems occur.

ERROR CODES

When "SLACK" of the warning indicator lights, error causes and its operating status are displayed on the display panel.

E - x x x x

MODE

01 : REC
 02 : REC PAUSE
 03 : THREAD
 04 : UNTHREAD
 05 : STOP
 08 : PLAY
 09 : FF
 0A : REW
 0b : REC REVIEW
 0C : CUE UP
 0E : FF SEARCH
 0F : REW SEARCH

ERROR CAUSE

10 : Drum drive voltage abnormality
 11 : No drum FG detected
 12 : No drum PG detected
 20 : Capstan drive current abnormality
 21 : No capstan FG-A detected
 22 : No capstan FG-B detected
 32 : No S reel FG detected
 42 : No T reel FG detected
 51 : Excessive function cam rotation time in the forward direction
 58 : Threading motor voltage abnormality

3-2. Error Message

The error message is superimposed on the viewfinder screen if any fault occurs during the power-on sequence or normal operations.

Error Message	Operation	Remedy
? (Blinking)	During power-on sequence	A fault has been detected in the camera or VTR (HUMID or SLACK). Open the DIAGNOSIS menu and check the unit.

3-3. DIAGNOSTIC Mode

The DIAGNOSTIC mode is used for checking the VTR.

Note

Use this mode with the tape stopped.

Switches/Buttons description

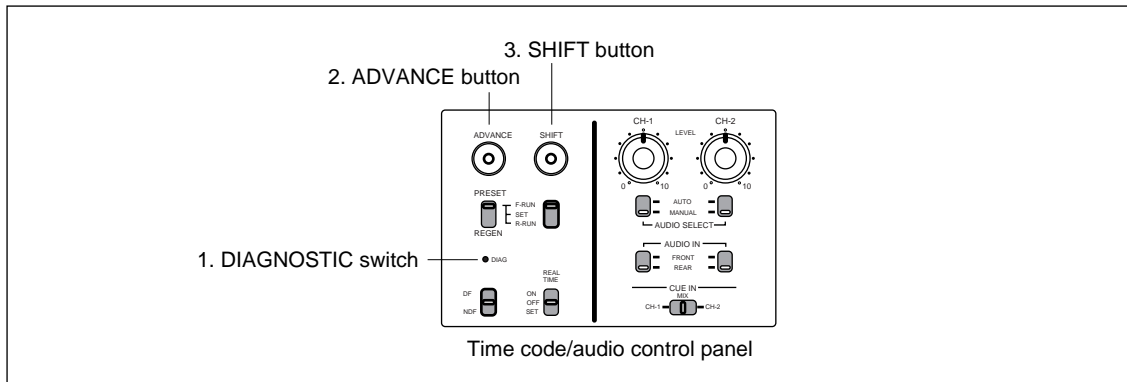

1. DIAGNOSTIC switch

Press to enter and exit the DIAGNOSTIC mode.

2. ADVANCE button

Shifts the left digit of menu one step.

3. SHIFT button

Shifts the right digit of menu one step.

OPERATION

1. Press the DIAGNOSTIC switch on the side panel with a stick tip, etc. to enter the DIAGNOSTIC mode.
2. To shift the menu, press the ADVANCE or SHIFT button.
 ADVANCE button : Shifts the left digit one step at a time.
 SHIFT button : Shifts the right digit one step at a time.
3. To exit the DIAGNOSTIC mode, press the DIAGNOSTIC switch again.

Section 4

Setup Menu

4-1. Setup Menu

The setup menu is used for selecting various setting values, items displayed on the viewfinder screen, the method of displaying, and adjustments. The menu is displayed on the viewfinder screen. The menu can also be displayed by connecting an external monitor to the MONITOR OUT connector.

Structure of Setup Menu

The setup menu is composed of the following menus.

- OPERATION menu
- PAINT menu
- MAINTENANCE menu
- FILE menu
- DIAGNOSIS menu

Note

Beside above menus, the TOP menu is provided for indicating the whole configuration of the menu items.

Selecting the Menu

The menus to be displayed on the viewfinder screen can be selected by the switches on the IF-819 board (S300-1 to S300-4). This unit is set to display all menu at the factory setting.

() : Shows the factory setting

Switch Settings

Setup Menu

S300-1	S300-2	S300-3	S300-4	OPERATION	PAINT	MAINTENANCE	FILE	DIAGNOSIS
(OFF)	(OFF)	(OFF)	(OFF)	Yes	Yes	Yes	Yes	Yes
ON	OFF	OFF	OFF	Yes	Yes	Yes	No	Yes
OFF	ON	OFF	OFF	Yes	Yes	No	No	Yes
ON	ON	OFF	OFF	Yes	No	No	No	Yes
OFF	OFF	ON	OFF	Yes	No	No	No	No

Equipment Required

2-type viewfinder HDVF-20A (or black-and-white monitor)

A battery, or an AC adapter AC-550/550CE, etc. for supplying the power to the camcorder.

Switches

DISPLAY switch

- ON** : Displays characters and messages indicating the settings and operating status of the unit on the viewfinder screen.
- OFF** : Turns off all the displays on the viewfinder screen.
- MENU** : Displays the setup menu on the viewfinder screen.

Rotary Encoder

Selects the items displayed on the viewfinder screen and changes settings.

MENU switch

- STATUS** : Allows you to check the current setting.
- CANCEL** : Cancels the menu setting mode and returns to the page selection mode or TOP menu.

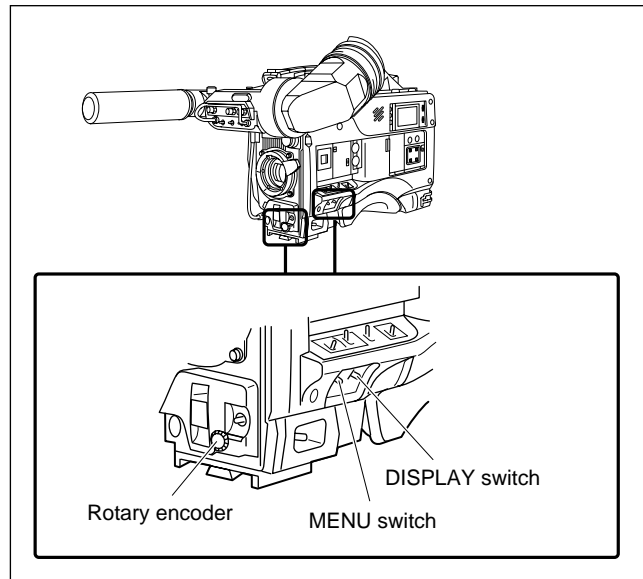

Basic Operations

1. Displaying the menu
To display the OPERATION menu, turn the power on and set the DISPLAY switch to "MENU".
To display the other menus, set the DISPLAY switch from "OFF" to "MENU" while pressing the rotary encoder, and obtain the TOP menu screen. Turning the rotary encoder, select the menu to be displayed, and press the rotary encoder.
2. To change pages, set the cursor to the page number and turn the rotary encoder.
3. To shift the cursor, turn the rotary encoder. (Pressing the rotary encoder determines the setting.)
4. To change a setting value, set the cursor to the item to be changed and press the rotary encoder, then the cursor turns to "?" and the value changes by turning the rotary encoder.
(Turning it fast, the value changes greatly, while turning it slowly, the value changes slightly for fine adjustment.) To determine the setting, press the rotary encoder, and to cancel the change, press the MENU switch toward the cancel side.
5. By every set of the MENU switch to "CANCEL", the screen returns to the item selection mode, page selection mode, and then TOP menu*.
6. To exit from the menu, set the DISPLAY switch to "OFF".

* : The page selection mode is available, only when the basic operation step1 was performed and the operation started from the TOP menu.

Displaying characters on an external monitor

When you want to display characters including the menu on an external monitor, proceed as follows.

1. Displaying characters (including the menu)
While pressing the MENU switch toward the "CANCEL" side, set the DISPLAY switch from "OFF" to "MENU".
2. To remove the characters/menu from the external monitor, while pressing the MENU switch towards the "CANCEL" side, set the DISPLAY switch from "MENU" to "OFF".

4-2. TOP Menu

To display the OPERATION menu, set the DISPLAY switch to MENU. To display the other menus, select the desired menu on the TOP menu screen. The TOP menu can be displayed by setting the DISPLAY switch from OFF to MENU while pressing the rotary encoder.

Notes

- To select the menu to be displayed on the viewfinder, switch setting on the IF-819 board is required. For details, refer to “Selecting the Menu” in Section 4-1.
- The display screen at power on is changeable. For change, refer to MENU RESUME item in OTHERS 2 Page of the MAINTENANCE menu.

TOP MENU

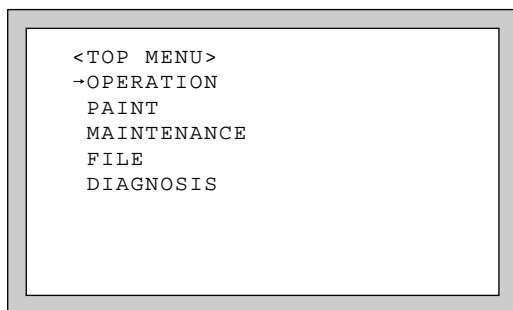

Menu	Description
OPERATION	This menu consists of VF screen display items to be set by a camera operator.
PAINT	This menu consists of general paint operation items such as white.
MAINTENANCE	This menu consists of paint items used less frequently such as shading adjustment and items required for the maintenance of the camera such as system change.
FILE	This menu is used for performing file operations such as saving the reference file.
DIAGNOSIS	This menu describes the self-diagnosis and VTR status, etc.

4-3. OPERATION Menu

The OPERATION menu consists of the items that a camera operator can set when using this camera, such as VF screen display setting.

VF DISPLAY page

In the VF DISPLAY Page, the items to be displayed on the viewfinder screen can be selected and the displaying method can also be set.

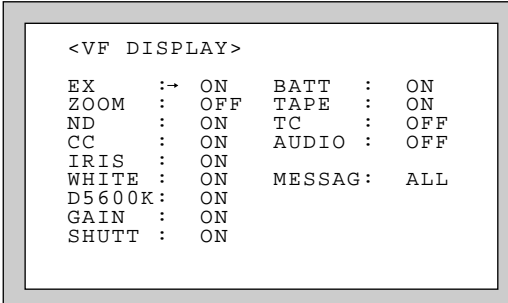

(Display is initial values.)

Item	Setting	Description
EX	3S, ON, OFF	Sets the extender display. ^{a)}
ZOOM	3S, ON, OFF	Sets the zoom position display. ^{a)}
ND	3S, ON, OFF	Sets the ND filter display. ^{a)}
CC	3S, ON, OFF	Sets the CC filter display. ^{a)}
IRIS	3S, ON, OFF	Sets the iris value display. ^{a)}
WHITE	3S, ON, OFF	Sets the white balance memory display. ^{a)}
D5600K	3S, ON, OFF	Sets the D5600K mode display. ^{a)}
GAIN	3S, ON, OFF	Sets the gain value display. ^{a)}
SHUTT	3S, ON, OFF	Sets the shutter speed/mode/reading mode display. ^{a)}
BATT	3S, ON, OFF	Sets the power supply voltage display. ^{a)}
TAPE	3S, ON, OFF	Sets the tape remainder display. ^{a)}
TC	3S, ON, OFF	Sets the time code display. ^{a)}
AUDIO	3S, ON, OFF	Sets the audio level display. ^{a)}
MESSAG	ALL, WRN, AT, OFF	Sets a message to be displayed at the center on the VF screen when each setting is changed.

Message			
	Warning ^{b)}	Auto setup ^{c)}	Status ^{d)}
ALL	○	○	○
AT	○	○	×
WRN	○	×	×
OFF	×	×	×

a) 3S: Displays for three seconds on the VF screen when a status is changed.
 ON: Displays all the time.
 OFF: Displays nothing.

b) Warning: Messages about the diagnosis information of the boards.

c) Auto setup: Message on auto setup.

d) Status: Message showing the status when the setting is changed with the switches on the front panel or the side panel.

'!' IND page

This item sets the function to light up the attention (!) indicator of VF On or OFF (IND) and also sets the lightning condition (NORMAL).

```

<'!' IND>
  [IND] [NORMAL]
ND      : → ON  1---
CC      : ON   -B--
WHITE  : ON   --B
D5600K : ON   OFF
GAIN    : ON   0dB
SHUTT   : ON   OFF
FAN     : ON   AUTO1
EXT     : ON   OFF
FORMAT : ON   23.98PsF

```

(Display is initial values.)

Item	Setting [IND]	[NORMAL]	Description
ND	ON, OFF	1, 2, 3, 4	On the condition that the ND filter is the same setting as the NORMAL setting, the indicator does not light up even if the IND setting is ON. Multiple conditions are selectable.
CC	ON, OFF	A, B, C, D	On the condition that the CC filter is the same setting as the NORMAL setting, the indicator does not light up even if the IND setting is ON. Multiple conditions are selectable.
WHITE	ON, OFF ^{e)}	P, A, B	On the condition that the white balance memory is the same setting as the NORMAL setting, the indicator does not light up even if the IND setting is ON. Multiple conditions are selectable.
D5600K	ON, OFF ^{e)}	ON, OFF	On the condition that the D5600K mode is the same setting as the NORMAL setting, the indicator does not light up even if the IND setting is ON. Multiple conditions are selectable.
GAIN	ON, OFF ^{e)}	L, M, H	On the condition that the gain switch is the same setting as the NORMAL setting, the indicator does not light up even if the IND setting is ON.
SHUTT	ON, OFF ^{e)}	ON, OFF	On the condition that the shutter is the same setting as the NORMAL setting, the indicator does not light up even if the IND setting is ON.
FAN	ON, OFF	AUTO1, AUTO2, MIN, MAX	On the condition that the fan mode is the same setting as the NORMAL setting, the indicator does not light up even if the IND setting is ON.
EXT	ON, OFF	ON, OFF	On the condition that the lens extender is the same setting as the NORMAL setting, the indicator does not light up even if the IND setting is ON.
FORMAT	ON, OFF	23.98PsF, 60I/ 59.94I, 50I, 30PsF/29.97PsF, 25PsF, 24PsF/23.98PsF	On the condition that the format is the same setting as the NORMAL setting, the indicator does not light up even if the IND setting is ON.

e) The setting turns to OFF forcefully when connecting to MSU (master setup unit).

MARKER page

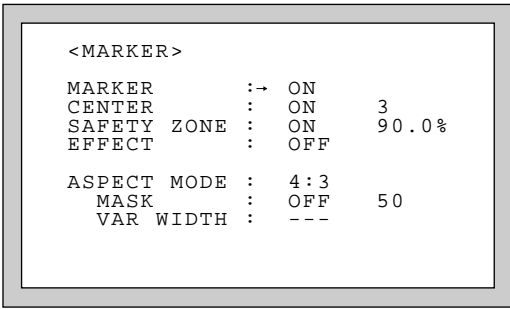

(Display is initial values.)

Item	Setting	Description
MARKER	ON, OFF	Sets all VF marker displays to ON or OFF.
CENTER	ON, OFF	Sets the center marker display to ON or OFF.
	1, 2, 3, 4	Selects the center marker. ^{f)}
SAFETY ZONE	ON, OFF	Sets the safety zone marker display to ON or OFF.
	80.0, 90.0, 92.5, 95.0	Sets the safety zone marker range.
EFFECT	ON, OFF	Sets the effective pixel area display to ON or OFF.
ASPECT MODE	16:9, 15:9, 15:9, 13:9 4:3, VAR H, VAR V, 1035, VISTA1 ^{g)} , VISTA2 ^{g)}	Selects the aspect mode.
MASK	ON, OFF	Sets the function for darkening the area other than the use area to ON or OFF. (When 16:9 is selected in the above ASPECT MODE, setting is disabled.)
	0 to 100	Sets the level of darkness in the area other than the use area. (For 16:9, setting is disabled.)
VAR WIDTH	0 to 1920 (VAR H)	Sets the aspect when VAR H is selected as the aspect mode.
	0 to 1080 (VAR V)	Sets the aspect when VAR V is selected as the aspect mode.

f)

Setting	1	2	3	4
VF screen				

g) The VISTA aspect ratio to the normal 16 : 9 ratio is as follows.
 VISTA1: 16 : 8.469
 VISTA2: 16 : 6.75

GAIN SW page

```

<GAIN SW>
LOW      :→ 0  dB
MIDDLE   :   6  dB
HIGH     :  12  dB

```

(Display is initial values.)

Item	Setting	Description
LOW	-3, 0, 3, 6, 12, 18	Sets the gain values corresponding to L, M, and H
MIDDLE	-3, 0, 3, 6, 12, 18	positions of the GAIN SW.
HIGH	-3, 0, 3, 6, 12, 18	

ZEBRA/VF DTL page

```

<ZEBRA/VF DTL>
ZEBRA     :→ ON
           :   1
ZEBRA1    :   70%
ZEBRA2    :  100%
VF DTL    :   0
           :  ON

```

(Display is initial values.)

Item	Setting	Description
ZEBRA	ON, OFF	Sets the function to display the zebra pattern on the VF screen to ON or OFF.
	1, 2, 1 & 2	Select the zebra pattern. (Settings of the video level 1 and 2 are performed in ZEBRA1 and ZEBRA2.
ZEBRA1	58 to 82 %	Sets the zebra 1 center video level.
ZEBRA2	88 to 112 %	Sets the zebra 2 lower limit video level.
VF DTL	-99 to 99	Sets the VF detail level.
	ON, OFF	Sets VF detail function to ON or OFF.

AUTO IRIS page

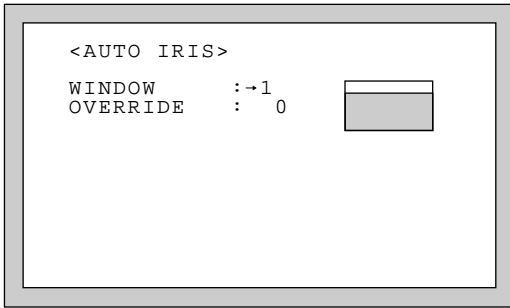

(Display is initial values.)

Item	Setting	Description
WINDOW	1, 2, 3, 4, 5, 6	Selects the auto iris window ^{h)} . (Same as the AUTO IRIS page in the MAINTENANCE menu.)
OVERRIDE	-99 to 99	Sets the reference value of the auto iris level by ± 2 focus. (Same as the AUTO IRIS page in the MAINTENANCE menu.) -99 (1 iris nearly closed) \leftrightarrow 99 (1 iris nearly open)

h)

Setting	1	2	3	4	5	6
VF screen						

indicates the auto iris window frame.

BATT ALARM page

```

<BATT ALARM>

BATT
TYPE :→LITHIUM
BEFORE END: 11.5V
END       : 11.0V

DC IN
TYPE :→AC ADP
BEFORE END: ---
END       : ---

```

(Display is initial values.)

Item	Setting	Description
BATT TYPE	LITHIUM, ANTON, OTHERS1 ⁱ⁾ , OTHERS2 ^{j)} , AC ADP ^{j)}	Selects the battery to be connected to the battery terminal. (Same as the BATT ALARM page in the MAINTENANCE menu.) By this setting, the battery alarm voltage indication in accordance with the features of the battery or the power supply becomes possible.
BEFORE END		Displays the alarm voltage indicating that the battery is wearing out. The voltage is set in the BATT ALARM page of the maintenance menu.
END		Displays the alarm voltage indicating that the battery has worn out. The voltage is set in the BATT ALARM page of the maintenance menu.
DC IN TYPE	LITHIUM, ANTON, OTHERS1 ⁱ⁾ , OTHERS2 ^{j)} , AC ADP ^{j)}	Selects the power running in the DC IN connector. (Same as the BATT ALARM page in the MAINTENANCE menu.) By this setting, the battery alarm voltage indication in accordance with the features of the battery or the power supply becomes possible.
BEFORE END		Displays the alarm voltage indicating that the DC power is wearing out. The voltage is set in the BATT ALARM page of the maintenance menu.
END		Displays the alarm voltage indicating that the DC power has worn out. The voltage is set in the BATT ALARM page of the maintenance menu.

- i) Select OTHERS1 and 2 when using the batteries other than LITHIUM, ANTON, AC ADP or the power supply.
j) Select the AC ADP, when using the AC/DC power supply of AC-550/550CE.

OTHERS page

```

<OTHERS>

D5600K: OFF →
ASSIGNABLE 1: OFF
ASSIGNABLE 2: OFF

```

(Display is initial values.)

Item	Setting	Description
D5600K	ON, OFF	To realize the color temperature of D5600K electrically, sets the D5600K mode ON or OFF.
ASSIGNABLE 1	OFF, D12dB, D24dB	Selects the function for allocating to ASSIGNABLE switch 1 and 2.
ASSIGNABLE 2	VTR S/S REC REVIEW	OFF : allocates no function in the digital circuit. D12dB : Digital pixel 12dB function D24dB : Digital pixel 24dB function VTR S/S : VTR start/stop function REC REVIEW : Function same as the RET switch of the lens.

OPERATOR FILE page

```

<OPERATOR FILE>

→ READ (MS →CAM)
WRITE (CAM→ MS)

PRESET

FILE ID:
CAM CODE:
DATE:
    
```

Item	Setting	Description
READ (MS → CAM)	Press the rotary encoder to execute the operation.	Reads from the memory stick of the operator file.
WRITE (CAM → MS)	Press the rotary encoder to execute the operation.	Stores in the memory stick of the operator file.
PRESET	Press the rotary encoder to execute the operation.	Returns the values of the operator file items to the preset values.
FILE ID		Writes comments to a file.
CAM CODE		Displays the camera name of the file created.
DATE		Displays the date when the file was created.

LENS FILE page

```

<LENS FILE>

FILE :→1
HA14 x 8
F2.0
    
```

(Display is initial values.)

Item	Setting	Description
FILE	1 to 16	Selects the file matching with the mounted lens from the sixteen lens files.
HA14 × 8		Displays each lens name.
F2.0		Displays the open edge F value.

4-4. PAINT Menu

The PAINT menu contains overall general paint adjustment items, such as white adjustment.

SW STATUS page

```

<SW STATUS>
FLARE      : ON
GAMMA     : ON
BLK GAM   : OFF
KNEE      : ON
WHT CLIP  : ON
DETAIL    : ON
LVL DEP   : ON
SKIN DTL  : OFF
MATRIX    :-OFF
  
```

(Display is initial values.)

Item	Setting	Description
FLARE	ON, OFF	Sets the flare correction circuit to ON or OFF.
GAMMA	ON, OFF	Sets the gamma correction function to ON or OFF.
BLK GAM	ON, OFF	Sets the black gamma correction function to ON or OFF.
KNEE	ON, OFF	Sets the knee correction circuit to ON or OFF.
WHT CLIP	ON, OFF	Sets the white clip function to ON or OFF.
DETAIL	ON, OFF	Sets the function for attaching the detail signal for improving the resolution to ON or OFF.
LVL DEP	ON, OFF	Sets the level dependence function to ON or OFF.
SKIN DTL	ON, OFF	Sets the skin detail function to ON or OFF.
MATRIX	ON, OFF	Sets the linear matrix correction function to ON or OFF.

VIDEO LEVEL page

```

<VIDEO LEVEL>

  WHITE  :-> [R] [G] [B] [M]
          :  0  0  0
  BLACK  :  0  0  0  0
  FLARE   :  0  0  0  0
  GAMMA   :  0  0  0  0
  V MOD   :  0  0  0  0

  FLARE   : ON
  V MOD   : ON
  TEST    : OFF
    
```

(Display is initial values.)

Item	Setting	Description
WHITE	-99 to 99	Adjusts the white level of R, G, B.
BLACK	-99 to 99	Adjusts the black level of R, G, B and master.
FLARE	-99 to 99	Adjusts the flare level of R, G, B and master.
GAMMA	-99 to 99	Adjusts the gamma correction curve of the R, G, B and master.
V MOD	-99 to 99	Adjusts the V modulation shading of R, G, B and master.
FLARE	ON, OFF	Sets the flare correction circuit to ON or OFF.
V MOD	ON, OFF	Sets the V modulation shading to ON or OFF.
TEST	OFF, 1, 2	Selects the test signal. OFF : Provides no test signals. 1 : Provides the test signal of the sawtooth waveform. 2 : Provides the test signal of the sawtooth waveform of digital output.

GAMMA page

```

<GAMMA>

  LEVEL  :-> [R] [G] [B] [M]
          :  0  0  0  0
  COARSE : 0.45
  TABLE : STANDARD
          : 2
  GAMMA  : ON
  TEST   : OFF
    
```

(Display is initial values.)

Item	Setting	Description
LEVEL	-99 to 99	Adjusts the gamma correction curve of the R, G, B and master.
COARSE	0.40, 0.45, 0.50	Sets the correction curve of the master gamma in steps.
TABLE	STANDARD, FILM, 1, 2, 3, ...	Selects the gamma table category. Selects the table No. in the gamma table category.
GAMMA	ON, OFF	Sets the gamma correction function to ON or OFF.
TEST	OFF, 1, 2	Selects the test signal OFF : Provides no test signals. 1 : Provides the test signal of the sawtooth waveform. 2 : Provides the test signal of the sawtooth waveform of digital output.

BLK GAMMA page

```

<BLK GAMMA>

RGB      [R] [G] [B] [M]
LEVEL  :→  0   0   0   0
RANGE  :  15%
        : OFF

Y
LEVEL  :    0
RANGE  :  15%
        : OFF

TEST   : OFF

```

(Display is initial values.)

Item	Setting	Description
RGB LEVEL	-99 to 99	Adjusts the black gamma of the R, G, B and master.
RGB RANGE	15, 25, 35, 50%	Sets the upper limit of the video level which the RGB black gamma affects.
	ON, OFF	Sets the RGB black gamma correction function to ON or OFF.
Y LEVEL	-99 to 99	Adjusts the Y black gamma to adjust the contrast without changing the chroma phase of the dark part.
Y Range	15, 25, 35, 50%	Sets the upper limit of the video level which the Y black gamma affects.
	ON, OFF	Sets the Y black gamma correction function to ON or OFF.
TEST	OFF, 1, 2	Selects the test signal. OFF : Provides no test signals. 1 : Provides the test signal of the sawtooth waveform. 2 : Provides the test signal of the sawtooth waveform of digital output.

LOW KEY SAT page

```

<LOW KEY SAT>

LEVEL   : 0
BLK CLIP : 0
        : OFF

```

(Display is initial values.)

Item	Setting	Description
LEVEL	-99 to 99	Sets the saturation of the dark part.
BLK CLIP	-99 to 99	Sets the lower limit of the video level which the low key saturation affects.
	ON, OFF	Sets the low key saturation to ON or OFF.

KNEE page

```

<KNEE>

POINT   :->  [R] [G] [B] [M]
SLOPE   :    0  0  0  0
WHT CLP :    0  0  0  0
KNEE SAT LEVEL  0

KNEE    : ON
KNEE SAT : ON
WHT CLIP : ON
TEST    : OFF
    
```

(Display is initial values.)

Item	Setting	Description
POINT R/G/B/M	-99 to 99	Sets the knee point level when the settings of the auto knee function of the R, G, B and master are OFF.
SLOPE R/G/B/M	-99 to 99	Sets the knee slope level when the settings of the auto knee function of the R, G, B and master are OFF.
WHT CLP R/G/B/M	-99 to 99	Sets the white clip level of the R, G, B and master.
KNEE SAT LEVEL	-99 to 99	Sets the knee saturation level.
KNEE	ON, OFF	Sets the knee correction circuit to ON or OFF.
KNEE SAT	ON, OFF	Sets the knee saturation function to ON or OFF.
WHT CLIP	ON, OFF	Sets the white clip function to ON or OFF.
TEST	OFF, 1, 2	Selects the test signal. OFF : Provides no test signals. 1 : Provides the test signal of the sawtooth waveform. 2 : Provides the test signal of the sawtooth waveform of digital output.

DETAIL 1 page

```

<DETAIL 1>

LEVEL   : [M] [WHT][BLK]
LIMITER :    0    0    0
CRISP   :    0
HV RATIO :    0
FREQ    :    0
LVL DEP :    0

DETAIL  : ON
LVL DEP : ON
    
```

(Display is initial values.)

Item	Setting	Description
LEVEL	-99 to 99	Sets the general level of the detail signal.
LIMITER M/WHT/BLK	-99 to 99	Sets the level for clipping the excessive detail signal.
CRISP	-99 to 99	Sets the level for suppressing the noise components contained in the detail signal.
HV RATIO	-99 to 99	Sets the ratio between H detail signal and V detail signal.
FREQ	-99 to 99	Sets the frequency of the H detail signal.
LVL DEP	-99 to 99	Sets the level for suppressing the detail amount in the dark part.
DETAIL	ON, OFF	Sets the function for attaching the detail signal for improving the resolution to ON or OFF.
LVL DEP	ON, OFF	Sets the level depend function to ON or OFF.

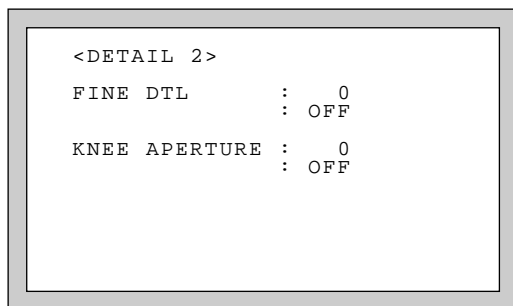
DETAIL 2 page

(Display is initial values.)

Item	Setting	Description
FINE DTL	-99 to 99	Sets the general level of the fine detail ^{a)} signal.
	ON, OFF	Sets the fine detail ^{a)} function to ON or OFF.
KNEE APERTURE	-99 to 99	Sets the knee aperture ^{b)} level.
	ON, OFF	Sets the knee aperture ^{b)} function to ON or OFF.

- a) This function changes the width of the edge without changing the details edge level in the horizontal direction.
 b) This function compensates for decreases by the knee aperture in the detail level at the high luminance level part of the camera subject.

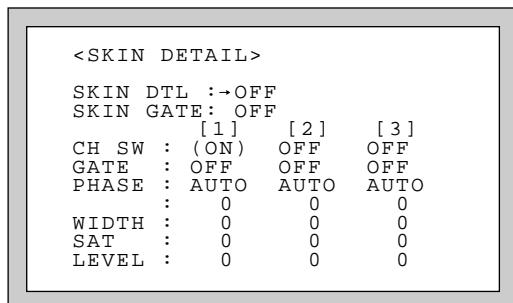
SKIN DETAIL page

(Display is initial values.)

Item	Setting	Description
SKIN DTL	ON, OFF	When this setting is ON, the setting [1] of the channel 1 is always set ON. Sets the skin detail function to ON or OFF.
SKIN GATE	ON, OFF	Sets the zebra indication of the skin tone detail portion to ON or OFF.
CH SW	ON, OFF	Sets each channel of the skin detail function to ON or OFF. Channel 1 is fixed to ON.
GATE	ON, OFF	Sets each channel of the skin gate function to ON or OFF.
PHASE	AUTO ^{c)}	Set automatically the region of each channel the skin detail function affects.
	0 to 359	Sets the center phase of the chroma phase the skin tone detail function affects to each channel.
WIDTH	-99 to 99	Adjusts the chroma phase width of the skin tone detail function to each channel.
SAT	-99 to 99	Adjusts the saturation level of the skin tone detail function to each channel.
LEVEL	-99 to 99	Sets the skin tone detail amount to each channel.

- c) Method of executing AUTO
 1. Set the cursor to the AUTO and press the rotary encoder, then the square-shaped zebra pattern is displayed on the viewfinder.
 2. Set the zebra pattern to the color to be given the effect of the skin tone detail and press the rotary encoder to select the phase.

USER MATRIX page

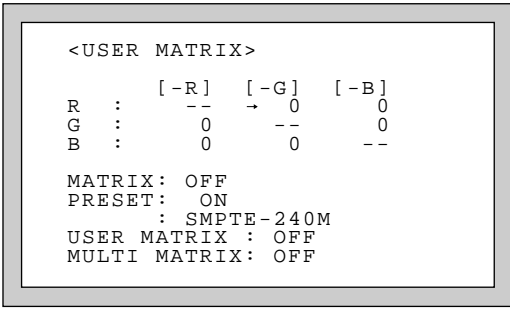

(Display is initial values.)

Item	Setting	Description
R-G, R-B,	-99 to 99	Sets the linear matrix coefficient for each R-G, R-B, G-R, G-B, B-R, and B-G.
G-R, G-B,	-99 to 99	
B-R, B-G,	-99 to 99	
MATRIX ^{d)}	ON, OFF	Sets the linear matrix correction function to ON or OFF.
PRESET ^{d)}	ON, OFF	Sets the linear matrix correction coefficient set at factory to ON or OFF. (When the MATRIX setting is OFF, this setting is unavailable, "--" is displayed showing invalid.)
	SMPTE-240M, ITU-709, SMPTE-WIDE, NTSC, EBU ITU-609	Selects the linear matrix correction coefficient set at factory.
USER MATRIX ^{d)}	ON, OFF	Sets the linear matrix correction function set by the user to ON or OFF. (When the MATRIX setting is OFF, this setting is unavailable, "--" is displayed showing invalid.)
MULTI MATRIX ^{d)}	ON, OFF	Sets the multi matrix correction function to ON or OFF. (When the MATRIX setting is OFF, this setting is unavailable, "--" is displayed showing invalid.)

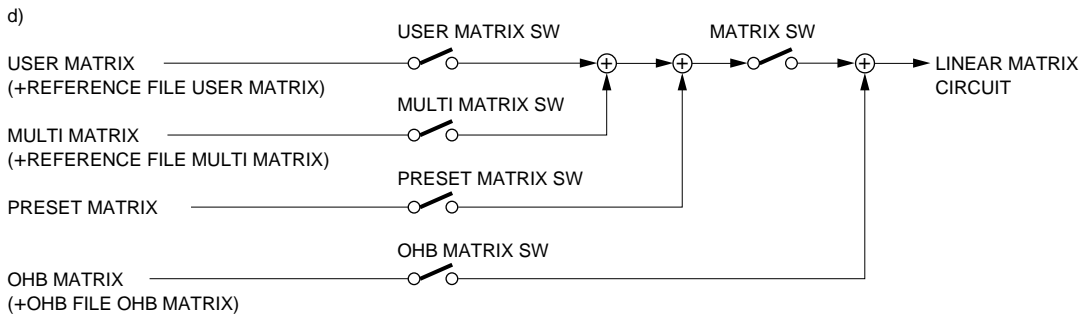

- USER MATRIX : Linear matrix that can change R-G and R-B in the conventional camera.
- MULTI MATRIX : Linear matrix that divides the chroma phase width of the linear matrix into 16 segments and can adjust each individually.
- PRESET MATRIX : Addition of the linear matrix value fixed in the standard specification.
- OHB MATRIX : Linear (multi) matrix for matching the color between the cameras.

MULTI MATRIX page

```

<MULTI MATRIX>
PHASE  :→  0
HUE    :    0
SAT    :    0
      ALL CLEAR

MATRIX : OFF
PRESET : ON
      : SMPTE-240M
USER MATRIX : OFF
MULTI MATRIX: OFF

```

(Display is initial values.)

Item	Setting	Description
PHASE	0, 23, 45, 68, 90, 113, 135, 158, 180, 203, 225, 248, 270, 293, 315, 338	Sets the region the multi matrix correction function can be changed. (sixteen-axis mode)
HUE	-99 to 99	Adjusts the color phase the multi matrix correction function affects in every sixteen-axis mode.
SAT	-99 to 99	Adjusts the saturation level the multi matrix correction function affects in every sixteen-axis mode.
ALL CLEAR	Press the rotary encoder to execute the operation	Clears the HUE and SAT values in each phase to 0. (The values in the reference file are not cleared.)
MATRIX ^{d)}	ON, OFF	Sets the liner matrix correction function to ON or OFF.
PRESET ^{d)}	ON, OFF	Sets the multi matrix correction coefficient set at the factory to ON or OFF. (When MATRIX setting is OFF, this setting is unavailable, "- -" is displayed showing invalid.)
	SMPTE-240M, ITU-709, SMPTE-WIDE, NTSC, EBU ITU-609	Selects the multi matrix correction coefficient set at the factory.
USER MATRIX ^{d)}	ON, OFF	Sets the multi matrix correction function set by the user to ON or OFF. (When MATRIX setting is OFF, this setting is unavailable, "- -" is displayed showing invalid.)
MULTI MATRIX ^{d)}	ON, OFF	Sets the multi matrix correction function to ON or OFF. (When MATRIX setting is OFF, this setting is unavailable, "- -" is displayed showing invalid.)

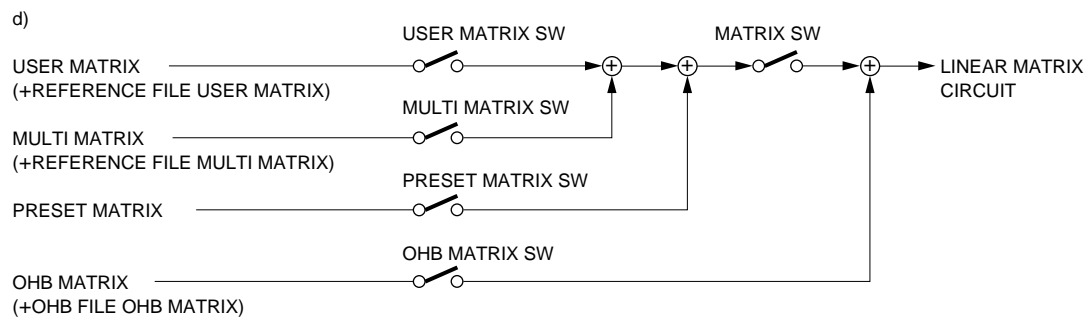

USER MATRIX : Linear matrix that can change R-G and R-B in the conventional camera.

MULTI MATRIX : Linear matrix that divides the chroma phase width of the linear matrix into 16 segments and can adjust each individually.

PRESET MATRIX : Addition of the linear matrix value fixed in the standard specification.

OHB MATRIX : Linear (multi) matrix for matching the color between the cameras.

SHUTTER page

```

<SHUTTER>
SHUTTER :→OFF
          : 1/125
ECS FREQ: 30.0Hz
S-EVS   : OFF
          : 0%

```

(Display is initial values.)

Item	Setting	Description
SHUTTER	ON, OFF	Sets the shutter/ECS mode to ON or OFF.
	Table below ^{e)}	Sets the shutter speed. (The selectable shutter speed varies with each format.)
ECS FREQ	Table below ^{f)}	Sets the ECS frequency. (The selectable ECS frequency variable region varies with each format.)
S-EVS	ON, OFF	Sets the S-EVS mode to ON or OFF.
	0 to 100 %	Sets the S-EVS. (When the format setting 30PsF, 29.97PsF, 25PsF, 24PsF and 23.98PsF, this setting is unavailable. "--" is displayed showing invalid.)

e) Shutter speed setting

Format	Shutter speed
60I/59.94I	1/100, 1/125, 1/250, 1/500, 1/1000, 1/2000
50I	1/60, 1/125, 1/250, 1/500, 1/1000, 1/2000
30PsF/29.97PsF	1/40, 1/60, 1/120, 1/125, 1/250, 1/500, 1/1000
25PsF	1/33, 1/50, 1/100, 1/125, 1/250, 1/500, 1/1000
24PsF/23.98PsF	1/32, 1/48, 1/96, 1/125, 1/250, 1/500, 1/1000

f) ECS frequency setting

Format	ECS
60I/59.94I	30.0 to 5600Hz
50I	25.0 to 5600Hz
30PsF/29.97PsF	30.4 to 2800Hz
25PsF	25.3 to 2300Hz
24PsF/23.98PsF	24.3 to 2300Hz

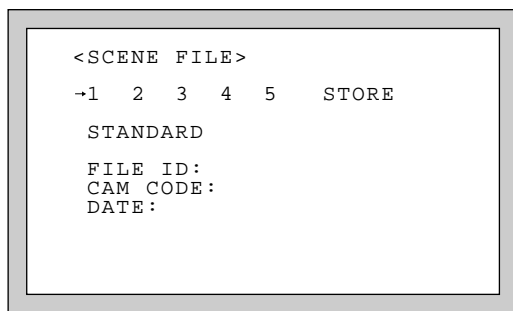
SCENE FILE page

Item	Setting	Description
1		Saves and calls the scene file (the data painted in accordance with the shooting scene.) (Same as the SCENE FILE page in the FILE menu.) How to save 1. Set "→" to STORE and press the rotary encoder, then "STORE NO?" will blink. 2. Select the file No. (1 to 5) for saving. (If data is already saved, the data will be replaced with new one.) How to call Set "→" to the file No. to be called up and press the rotary encoder. During calling up, the number is highlighted, and to cancel the operation, press the rotary encoder during the highlighting.
2		
3		
4		
5		
STORE		
	STANDARD	Returns the current paint adjustment amount and switch settings to the reference values.
	FILE ID	Writes comments to a file.
	CAM CODE	Displays the camera name of the file created.
	DATE	Displays the date when the file was created.

4-5. MAINTENANCE Menu

This menu consists of paint items used less frequently such as shading adjustment and items required for the camera maintenance such as system change.

AUTO SETUP page

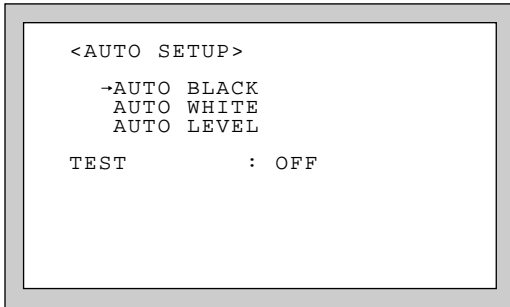

(Display is initial values.)

Item	Setting	Description
AUTO BLACK	Press the rotary encoder to execute the operation.	Starts the automatic black balance adjustment. (Pressing the rotary encoder during the execution, the execution is canceled.)
AUTO WHITE	Press the rotary encoder to execute the operation.	Starts the automatic white balance adjustment. (Pressing the rotary encoder during the execution, the execution is canceled.)
AUTO LEVEL	Press the rotary encoder to execute the operation.	Starts the automatic level adjustment of the camera circuit. (Pressing the rotary encoder during the execution, the execution is canceled.)
TEST	OFF, 1, 2	Selects the test signal. OFF : Provides no test signals. 1 : Provides the test signal of the sawtooth waveform. 2 : Provides the test signal of the sawtooth waveform of digital output.

WHITE SHADING page

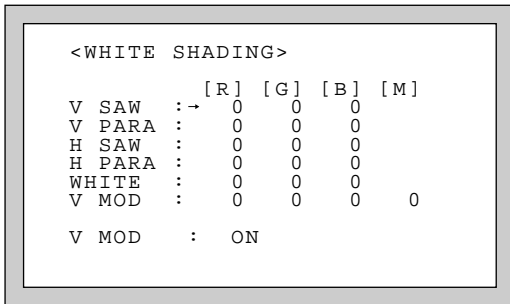

(Display is initial values.)

Item	Setting	Description
V SAW R/G/B	-99 to 99	Adjusts the white shading V SAW correction amount of the R,G,B.
V PARA R/G/B	-99 to 99	Adjusts the white shading V PARA correction amount of R,G,B.
H SAW R/G/B	-99 to 99	Adjusts the white shading H SAW correction amount of R,G,B.
H PARA R/G/B	-99 to 99	Adjusts the white shading H PARA correction amount of R,G,B.
WHITE R/G/B	-99 to 99	Adjusts the white level of R,G,B.
V MOD R/G/B/M	-99 to 99	Adjusts the V modulation shading of R,G,B and master.
V MOD	ON, OFF	Sets the V modulation shading function to ON of OFF.

BLACK SHADING page

```

<BLACK SHADING>

V SAW  :→  [R] [G] [B] [M]
V PARA :    0  0  0
H SAW  :    0  0  0
H PARA :    0  0  0
BLK SET:    0  0  0
BLACK  :    0  0  0  0

MASTER GAIN : 0dB

```

(Display is initial values.)

Item	Setting	Description
V SAW R/G/B	-99 to 99	Adjusts the black shading V SAW correction amount of the R,G,B.
V PARA R/G/B	-99 to 99	Adjusts the black shading V PARA correction amount of R,G,B.
H SAW R/G/B	-99 to 99	Adjusts the black shading H SAW correction amount of R,G,B.
H PARA R/G/B	-99 to 99	Adjusts the black shading H PARA correction amount of R,G,B.
BLK SET R/G/B	-99 to 99	Adjusts the black set correction amount of R,G,B.
BLACK R/G/B/M	-99 to 99	Adjusts the black level of the R,G,B and master.
MASTER GAIN	-3, 0, 3, 6, 12, 18 dB	Sets the master gain.

OHB MATRIX page

```

<OHB MATRIX>

PHASE :→  0
HUE   :    0
SAT   :    0
      ALL CLEAR

MATRIX : OFF
OHB MATRIX: OFF

```

(Display is initial values.)

Item	Setting	Description
PHASE	0, 23, 45, 68, 90, 113, 135, 158, 180, 203, 225, 248, 270, 293, 315, 338	Set the region the OHB matrix correction function affects. (sixteen-axis mode)
HUE	-99 to 99	Adjusts the color phase the OHB matrix correction function affects in every sixteen-axis mode.
SAT	-99 to 99	Adjusts the saturation level the OHB matrix correction function affects in every sixteen-axis mode.
ALL CLEAR	Press the rotary encoder to execute the operation	Clears the HUE and SAT values in each phase to 0. (The values in the OHB file are not cleared.)
MATRIX	ON, OFF	Sets the linear matrix correction function to ON or OFF.
OHB MATRIX	ON, OFF	Sets the OHB matrix correction function to ON or OFF.

AUTO IRIS page

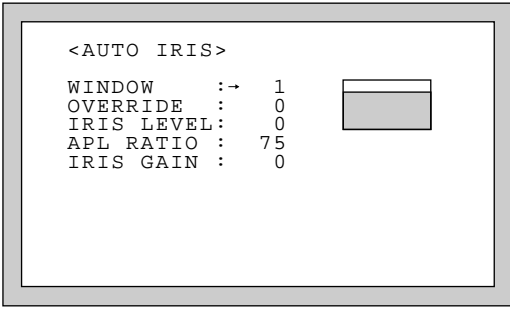

(Display is initial values.)

Item	Setting	Description
WINDOW	1, 2, 3, 4, 5, 6	Selects the auto iris window ^{a)} . (Same as the AUTO IRIS page in the OPERATION menu.)
OVERRIDE	-99 to 99	Sets the reference value of the auto iris level by ±2 focus. (Same as the AUTO IRIS page in the OPERATION menu.) -99 (1 iris nearly closed) ↔ 99 (1 iris nearly open)
IRIS LEVEL	-99 to 99	Sets the auto-iris level.
APL RATIO	-99 to 99	Sets the method of detecting the light amount of the auto iris. -99 (Peak light detection) ↔ 99 (Average value detection of whole screen)
IRIS GAIN	-99 to 99	Sets the iris gain.

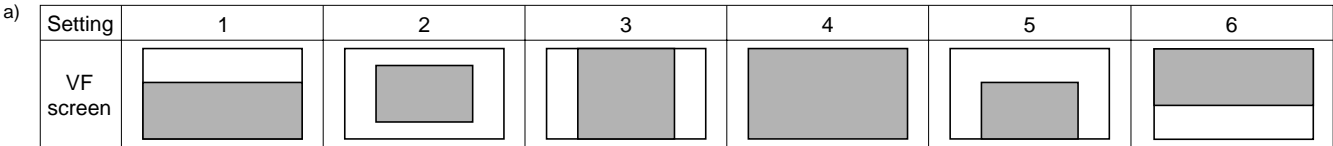

indicates the auto iris window frame.

CAM ID/DATE page

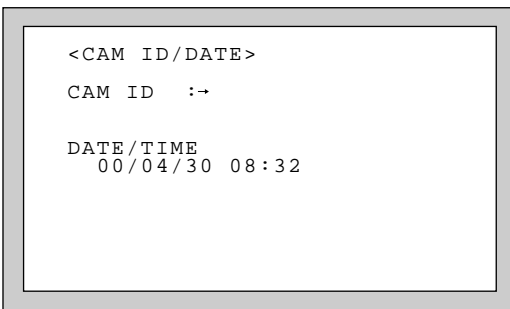

(Display is initial values.)

Item	Setting	Description
CAM ID		Sets the camera ID of less 14 characters consisting of alphanumeric, symbols and spaces.
DATE/TIME		Sets the present date and time. Note The way of indicating date is changeable. Refer to DATE TYPE of OTHER2 page in MAINTENANCE menu.

MULTI FORMAT page

```

<MULT FORMAT>

CURRENT  59.94I
NEXT    :→59.94I

 60I      50I   ***
59.94I    ***   ***

30PsF    25PsF 24PsF
29.97PsF ***   23.98PsF

```

(Display is initial values.)

Item	Setting	Description
CURRENT		Displays the format being currently selected. The currently selected format is highlighted in the line below.
NEXT		Selects the format when the power is turned on next time. A turn of the rotary encoder shifts the portion highlighted. Press the rotary encoder for determination. (The highlighted portion does not shift to the *** portion.)

VTR SETUP page

```

<VTR SETUP>

FF/REW AUDIO: EE
PB AUDIO CH : 1/2
AU REC CH3/4: AUTO
AU REC 1KHz : MUTE
AU EMPHASIS : ON
TC OUT      : TCG/PB
CTL TIMER   : 24H
REAL TIME   : AUTO

```

(Display is initial values.)

Item	Setting	Description
FF/REW AUDIO	CUE, EE	Sets the audio output during FF/REW.
PB AUDIO CH	1/2, 3/4	Sets the audio output channel during playback. 1/2 : Outputs CH 1/2. 2/4 : Outputs CH 3/4.
AU REC CH 3/4	AUTO, 1/2CH, MUTE	Sets the input signal to be recorded in CH3/4. AUTO : Selects the reverse input signal of CH1 and CH2 selected by AUDIO IN switch. 1/2 CH: Selects the same input signal of CH1 and CH2 selected by AUDIO IN switch. MUTE: Not records in CH3 and CH4.
AU REC 1KHz	MUTE, 0 dB, -20 dB	Selects whether to generate the 1 kHz test signal available from the internal SG when the color bar is selected. MUTE : Generates no signal. 0 dB : Generates 1 kHz, 0 dB. -20 dB : Generates 1 kHz, -20 dB.
AU EMPHASIS	ON, OFF	Sets the audio emphasis to ON or OFF.
TC OUT	TCG/PB, TCG	Sets the TC output.
CTL TIMER	24 H, ±10 H	Sets the CTL TIMER.
REAL TIME	AUTO, MANU	Sets the real time. MANU : Follows the setting of DF/NDF switch. AUTO : 60 Hz;NDF/59.94 Hz;DF

BATT ALARM page

```

<BATT ALARM>

BATT
TYPE :→LITHIUM
BEFORE END : 11.5V
END       : 11.0V

DC IN
TYPE :→AC ADP
BEFORE END : --
END       : --
    
```

(Display is initial values.)

Item	Setting	Description
BATT TYPE	LITHIUM, ANTON OTHERS1 ^{b)} , OTHERS2 ^{b)} , AC ADP ^{c)}	Selects the battery to be connected, to the battery terminal. (Same as the BATT ALARM page in the OPERATION menu.) By this setting, the battery alarm voltage indication in accordance with the features of the battery or the power supply becomes possible.
BEFORE END	11.0 to 11.7 V	Sets the alarm voltage indicating that the battery is wearing out. When the AC ADP is selected, this setting is unavailable, "--" is displayed showing invalid.
END	11.0 to 11.7 V	Sets the alarm voltage indicating that the battery has worn out. When the AC ADP is selected, this setting is unavailable, "--" is displayed showing invalid.
DC IN TYPE	LITHIUM, ANTON OTHERS1 ^{b)} , OTHERS2 ^{b)} , AC ADP ^{c)}	Selects the power running in the DC IN connector. (Same as the BATT ALARM page in the OPERATION menu.) By this setting, the battery alarm voltage indication in accordance with the features of the battery or the power supply becomes possible.
BEFORE END	11.0 to 11.7 V	Sets the alarm voltage indicating that the DC power is wearing out. When the AC ADP is selected, this setting is unavailable, "--" is displayed showing invalid.
END	11.0 to 11.7 V	Sets the alarm voltage indicating that the DC power has worn out. When the AC ADP is selected, this setting is unavailable, "--" is displayed showing invalid.

- b) Select OTHERS1 and 2 when using the batteries other than LITHIUM, ANTON, AC ADP or the power supply.
- c) Select the AC ADP, when using the AC/DC power supply of AC-550/550CE.

OTHERS1 page

```

<OTHERS 1>

H PHASE      :    0

MONITOR OUT
  Y:→0
  Pb/Pr:    0
    
```

(Display is initial values.)

Item	Setting	Description
H PHASE	-3072 to 1023	Adjusts the H phase.
MONITOR OUT		
Y	-30 to 30	Sets the Y output level at MONITOR OUT (BNC). ^{d)}
Pb/Pr	-30 to 30	Sets the Pb and Pr output level at MONITOR OUT (BNC). ^{d)}

- d) Used to adjust the error resulting from variation of 75 Ω termination.
Prior to adjusting the video level at MONITOR OUT, be sure to adjust video levels on the waveform monitor using a camera color-bar.

OTHERS2 page

```

<OTHERS 2>

FAN MODE      : AT1 (NORM)
MENU RESUME   : OPE MENU
DATE TYPE     : 1 Y/Mn/D
WHITE MEMORY  : 8

```

(Display is initial values.)

Item	Setting	Description
FAN MODE	AUTO1, AUTO2, MIN, MAX	Sets the fan mode. AUTO1 : normal mode AUTO2 : silent mode MIN : minimum rotation mode MAX : maximum rotation mode
MENU RESUME	OPE MENU, OFF, ALL	Sets the menu screen displayed when starting the menu. OPE MENU : Starts to display from the page in the operation menu, which was displayed at powering off of the previous time. OFF : Starts to display from the first page (VF DISPLAY) in the operation menu. ALL : Displays the menu screen, which was displayed at powering off of the previous time. Note To display the TOP menu, refer to Section 4-2.
DATE TYPE	1 to 6	Sets the date. 1: Y/Mn/D Year/Month/Date (Month should be showed by the figure.) 2: Mn/D Month/Date (Month should be showed by the figure.) 3: D/M/Y Date/Month/Year 4: D/M Date/Month 5: M/D/Y Month/Date/Year 6: M/D Month/Date
WHITE MEMORY	2, 8	Sets the number of white balance memory. 2: White balance memory can be set to A and B of WHITE BAL switch (total 2). 8: White balance memory can be set to A and B of each CC filter and WHITE BAL switch (total 8).

4-6. FILE Menu

FILE menu is used to operate the file such as saving the reference file.

OPERATOR FILE page

```

<OPERATOR FILE>

  →READ (MS →CAM)
  WRITE (CAM→ MS)

PRESET
STORE PRESET FILE

FILE ID:
CAM CODE:
DATE:

```

Item	Setting	Description
READ (MS → CAM)	Press the rotary encoder to execute the operation.	Reads the operator file from the memory stick.
WRITE (CAM → MS)	Press the rotary encoder to execute the operation.	Saves the operator file in the memory stick.
RESET	Press the rotary encoder to execute the operation.	Resets the operator file items to the preset values.
STORE PRESET FILE	Press the rotary encoder to execute the operation.	Registers the current setting values in the camera unit as the preset values of the operator file.
FILE ID		Writes comments to a file.
CAM CODE		Displays the camera name of the file created.
DATE		Displays the date when the file was created.

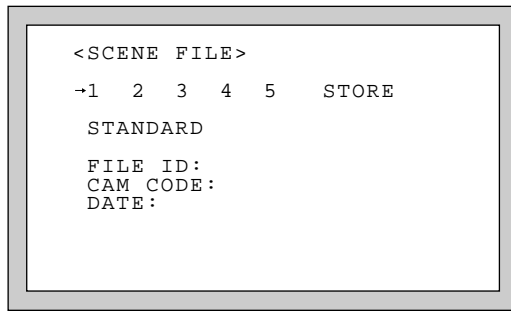
SCENE FILE page

Item	Setting	Description
1		Saves and calls the scene file (the data painted in accordance with the shooting scene.) (Same as the SCENE FILE page in the PAINT menu.)
2		
3		
4		
5		
STORE		<p>How to save</p> <ol style="list-style-type: none"> Set “→” to STORE and press the rotary encoder, then “STORE NO?” will blink. Select the file No. (1 to 5) for saving. (If data is already saved, the data will be replaced with new one.) <p>How to call</p> Set “→” to the file No. to be called up and press the rotary encoder. During calling up, the number is highlighted, and to cancel the operation, press the rotary encoder during the highlighting.
STANDARD		Returns the current paint adjustment amount and switch settings to the reference values.
FILE ID		Writes comments to a file.
CAM CODE		Displays the camera name of the file created.
DATE		Displays the date when the file was created.

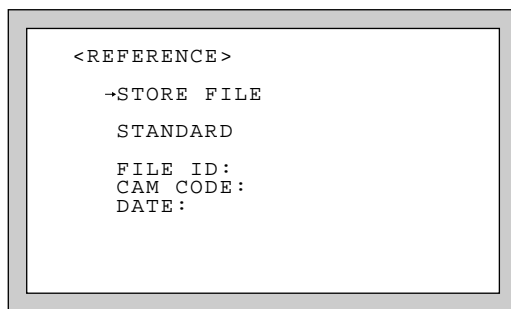
REFERENCE page

Item	Setting	Description
STORE FILE	Press the rotary encoder to execute the operation.	Registers the adjustment values of each item as the reference file.
STANDARD	Press the rotary encoder to execute the operation.	Returns the data registered in the reference file to the reference value.
FILE ID		Writes comments to a file.
CAM CODE		Displays the camera name of the file created.
DATE		Displays the date when the file was created.

LENS FILE page

```

<LENS FILE>
  -STORE FILE
FILE
  NO.   :->1
  NAME  : HJ18x7.8B
  F NO  : F1.5

CENTER MARKER
  H POS: 0
  V POS: 0
  STORE CENTER

```

(Display is initial values.)

Item	Setting	Description
STORE FILE	Press the rotary encoder to execute the operation.	Registers the adjustment values for each item (ex. the center marker position) as the lens file.
No.	1 to 16	Selects the file matching with the mounted lens from the sixteen lens files
NAME		Displays the lens file name in accordance with the No. (1 to 16) selected.
F NO	F1.0 to F3.4	Sets the open edge F value of the lens.
H POS	-20 to 20	Sets the center marker position (Horizontal) 20 (right) ↔ -20 (left)
V POS	-20 to 20	Sets the center marker position (Vertical) 20 (lower) ↔ -20 (upper)
STORE CENTER	Press the rotary encoder to execute the operation.	Registers the center marker position in the lens file being selected.

OHB FILE page

```

<OHB FILE>
  -STORE FILE

```

Item	Setting	Description
STORE FILE	Press the rotary encoder to execute the operation.	Stores the OHB file.

FILE CLEAR page

```

<FILE CLEAR>
-PRESET OPERATOR
REFERENCE (ALL)
 10 SEC CLEAR: OFF
LENS (CURRENT)
OHB WHITE SHAD
OHB BLACK SHAD
OHB ND OFFSET
OHB MATIX

```

(Display is initial values.)

Item	Setting	Description
PRESET OPERATOR	Press the rotary encoder to execute the operation.	Returns the preset value of the operator file set by the user to the original value at factory setting.
REFERENCE (ALL)	Press the rotary encoder to execute the operation.	Returns each adjustment value registered in the reference file to the original values at factory setting.
10 SEC CLEAR	ON, OFF	Sets ON or OFF the function to clear the reference value by continuing to push the rotary encoder for more than ten seconds with the cursor set to the reference item and "?" blinking. Note The setting returns to OFF when the unit is powered off.
LENS (CURRENT)	Press the rotary encoder to execute the operation.	Returns the lens file being selected to the original value at factory setting.
OHB WHITE SHAD		Clears the white shading in the OHB file to 0.
OHB BLACK SHAD		Clears the black shading in the OHB file to 0.
OHB ND OFFSET		Clears the ND offset in the OHB file to 0.
OHB MATRIX		Clears the matrix in the OHB file to 0.

4-7. DIAGNOSIS Menu

The DIAGNOSIS menu displays the self-diagnosis and VTR status, etc.

HOURS METER page

```

<HOURS METER>
DRUM RUNNING:->XXXXXXH
TAPE TRAVEL  : XXXXXXH
OPERATION    : XXXXXXH
THREADING    : XXXXXX
  
```

Item	Setting	Description
DRUM RUNNING	XXXXXXH	Displays the drum running time.
TAPE TRAVEL	XXXXXXH	Displays the tape running time.
OPERATION	XXXXXXH	Displays the operating time.
THREADING	XXXXXX	Displays the number of threading.

VTR STATUS page

```

<VTR STATUS>
CURRENT MODE:-PLAY
              : STOP
TAPE POS      : TOP
HUMID        : DET
REC INHIBIT  : OFF
SLACK        : XXX
              : XXX
              : XXX
              : XXX

```

Item	Setting	Description
CURRENT MODE	UNTHREAD, STOP, PLAY, FF, REW, THREAD, REC, R. PAUSE, R. PREVIEW	Displays the current and last VTR mode.
TAPE POS	TOP, TAPE OUT, STOP, PLAY, REC, REC PAUSE, SERACH, REW, EJECT, FF, REC REVIEW, END	Displays the tape position.
HUMID	DET, - - -	Displays the HUMID sensor status.
REC INHIBIT	ON, OFF	Sets the display of the REC INHIBIT status ON or OFF.
SLACK	XXX ^{a)} XXX ^{a)} XXX ^{a)} XXX ^{a)}	Displays the latest four pieces of slack information with the instruction code at the slack occurrence and the cause code. As for details of the instruction code at the slack occurrence and the cause code, refer to Error codes in Section 3-1.

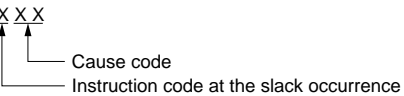
a) 

ROM VERSION page

```

<ROM VERSION>
IF   : V1.00
SV   : V1.00
SY   : V1.00

```

Item	Setting	Description
IF BOARD	X.XX	Displays the ROM version of the IF board.
SV BOARD	X.XX	Displays the ROM version of the SV board.
SY BOARD	X.XX	Displays the ROM version of the SY board.

BOARD STATUS page

```

<BOARD STATUS>

(CAM)          (VTR)
OHB  :OK      SV   :OK
VA   :OK      SY   :OK
DPR  :OK      DEC A :OK
AD   :OK      DEC B :OK
IF   :OK      VN   :OK
SG   :OK      EN   :OK
DA   :OK      ENC  :OK

```

Item	Setting	Description
(CAM)	OHB	OK, NG Displays the self-diagnosis status of the CCD block.
	VA	OK, NG Displays the self-diagnosis status of the VA board.
	DPR	OK, NG Displays the self-diagnosis status of the DPR board.
	AD	OK, NG Displays the self-diagnosis status of the AD board.
	IF	OK, NG Displays the self-diagnosis status of the IF board.
	SG	OK, NG Displays the self-diagnosis status of the SG board.
	DA	OK, NG Displays the self-diagnosis status of the DA board.
(VTR)	SV	OK, NG Displays the self-diagnosis status of the SV board.
	SY	OK, NG Displays the self-diagnosis status of the SY board.
	DEC A	OK, NG Displays the self-diagnosis status of the DEC A board.
	DEC B	OK, NG Displays the self-diagnosis status of the DEC B board.
	VN	OK, NG Displays the self-diagnosis status of the VN board.
	EN	OK, NG Displays the self-diagnosis status of the EN board.
	ENC	OK, NG Displays the self-diagnosis status of the ENC board.

Note

When “NG” is indicated, contact your local Sony Sales Office/Service Center.

TELE FILE page

```

<TELE FILE>
ID: 00000000000000000000000000000000
SIZE   : 0KBYTE
REMAIN : 0%
STATUS : NO LABEL

```

Item	Setting	Description
ID		Displays the ID of the memory label (20 characters) when using the cassette with the memory label attached.
SIZE	XXKBYTE	Displays the capacity of the memory label when using the cassette with the memory label attached.
REMAIN	XX%	Displays the empty space of the memory label when using the cassette with the memory label attached.
STATUS	STAND BY, NO LABEL, WHITE PROTECT LABEL, UNKNOWN FORMAT	<p>Displays the memory label status when using the cassette with the memory label attached.</p> <p>STAND BY: Indicates the memory label is writable.</p> <p>NO LABEL: Indicates the memory label is unavailable.</p> <p>WRITE PROTECT LABEL: Indicates overwrite on the memory label is prohibited.</p> <p>UNKNOWN FORMAT: Indicates in the memory label, the information of the different unit has been written in. (Writing is disabled.)</p>

Section 5 File System

The HDW-F900 is equipped with various file systems for managing data.

5-1. File Structure

The following six types of files are available.

1. Operator File

Stores the items displayed on the viewfinder and switch settings for camera operator. This file is stored in the memory stick, yet the video data (paint data) cannot be stored.

2. Preset Operator File

Stores the standard state of operator file items.

This file is be stored in the camera, yet video data (paint data) cannot be stored.

3. Scene File

Stores the temporary video setting data according to the scene. This file is stored in the camera.

4. Reference File

Stores the custom paint data adjusted by the video engineer. This file is stored in the camera and memory stick.

5. Lens File

Used for compensation of the deviation which generates by switching the lens extender from OFF to ON and for compensation of the difference in the characteristics between lenses. This file is stored in the camera.

6. OHB File

Used for adjustment of the CCD block maintenance. This file is stored in the camera.

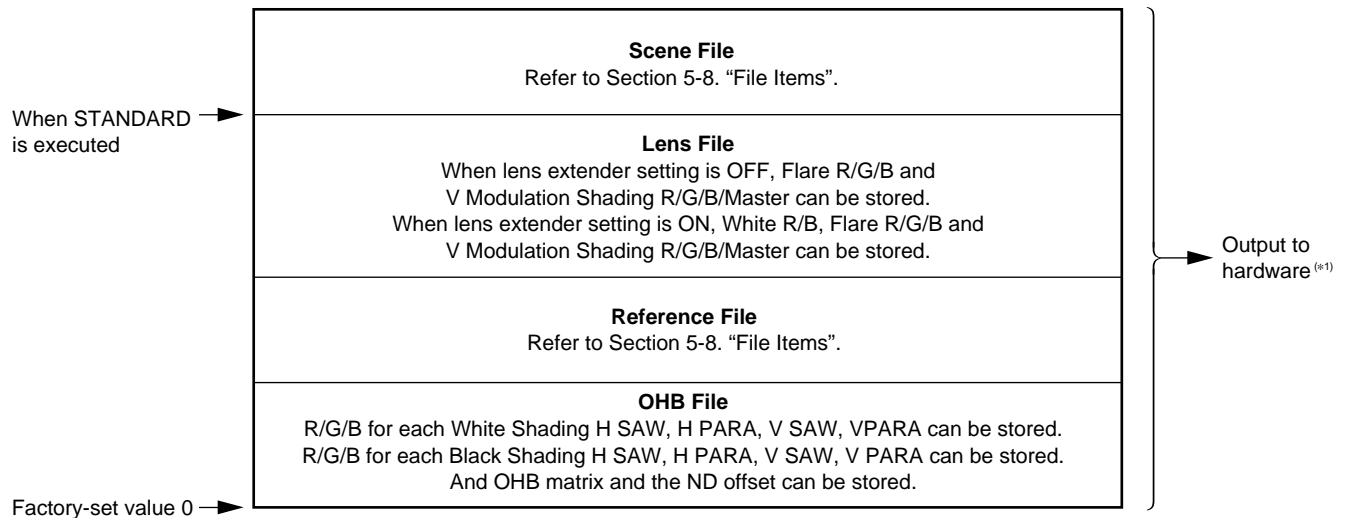

Fig. 5-1. Structure of Paint Related Files

(*1): The additional data of each file is sent to each circuit on the unit.

5-2. Operator File

Data is stored in the memory stick using the setup menu. As for the items to be stored, refer to Section 5-8, “File Items”.

Notes

- As for the setup menu, refer to Section 4.
- Operator files stored in the memory stick will not be read when the power is just turned ON. This file will only be read when READ is executed at the setup menu.
- The current operator file data is retained even when the power is turned off by the power switch.
- Before storing the file in the memory stick, make sure that the LOCK switch on the memory stick is in OFF position.

Storing the Operator File in the Memory Stick (Refer to step 1 of Fig. 5-2.)

Set the setup menu as follows, and store the current status in the memory stick.

OPERATION → OPERATOR FILE → WRITE (CAM → MS)

Reading the Operator File from the Memory Stick (Refer to step 2 of Fig. 5-2.)

Set the setup menu as follows.

OPERATION → OPERATOR FILE → READ (MS → CAM)

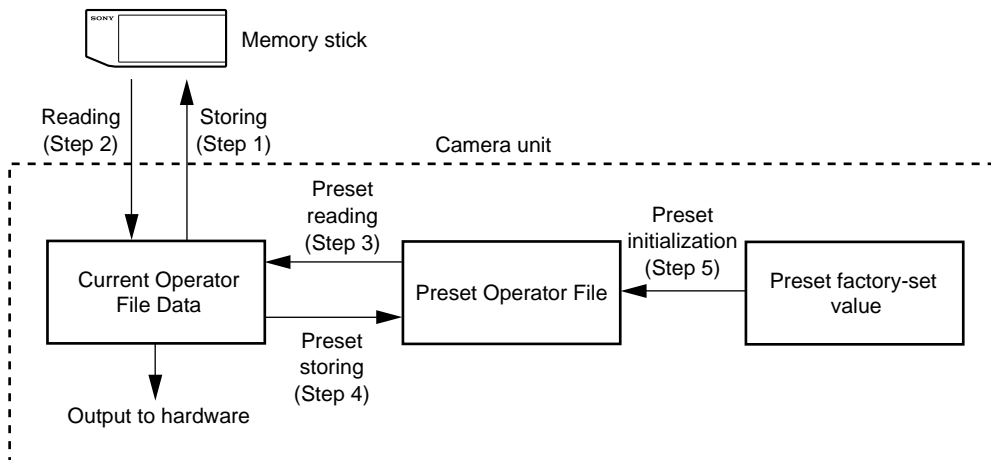

Fig. 5-2. Operating Procedure for Operator Files

5-3. Preset Operator File

The preset operator file is designed to store the standard values of the operator file items. There are two ways of calling the preset operator file; calling from the setup menu or reading at power ON. The items which can be stored on file are the same as Operator File.

Note

As for the setup menu, refer to Section 4.

Calling Using the Setup Menu (Refer to step 3 of Fig. 5-2.)

Set the setup menu as follows.

OPERATION → **OPERATOR FILE** → **PRESET**

Calling without Using the Setup Menu (Refer to step 3 of Fig. 5-2.)

Set the WHITE BAL switch to “PRST”, and while pushing the AUTO W/B BAL switch to the WHT side, set the POWER switch to ON.

Storing the Preset Values (Refer to step 4 of Fig. 5-2.)

The items of the preset values can be changed using the setup menu.

Set the setup menu as follows.

FILE → **OPERATOR FILE** → **STORE PRESET FILE**

Then, current status can be stored in the camera as Preset Operator File.

Initializing the Preset Values (Refer to step 5 of Fig. 5-2.)

Set the setup menu as follows to initialize the changed preset items to the factory-set data.

FILE → **FILE CLEAR** → **PRESET OPERATOR**

5-4. Registering the Scene File

The scene file is used for storing temporary video adjustment values according to the scene. 5 files can be stored and the data will be stored in the camera. The data can be stored using a setting menu or MSU (master setup unit).

As for the items to be stored, refer to Section 5-8,“ File Items”.

Notes

- Scene files are files for storing the differences from the reference file. Therefore when the reference file is changed, output of the scene file item corresponding with the item changed in the reference file is also changed.
- As for the setup menu, refer to Section 4.

Storing Using Setup Menu

- (1) Set the setup menu as follows.

PAINT → SCENE FILE → STANDARD

- (2) Change the scene file item to the desired value.

- (3) Set the setup menu as follows.

PAINT → SCENE FILE → STORE

Select the scene file number to be stored.

Calling Using Setup Menu and Clearing the Call

Select the scene file number called at the “SCENE FILE” page of the PAINT menu. A file currently being called is shown with its file No. highlighted. Selecting the number again clears the call and resets the state before calling.

Storing with MSU

- (1) Change the scene file item to the desired value.
- (2) Press “STORE” of the scene file, and press the STORE number.

Calling with MSU and Clearing the Call

Press the No. switch of the “SCENE FILE” to call. The switch also lights up. Press again to cancel the call and turn off the switch.

5-5. Registering Reference Files

This file can be stored and read using the setup menu or MSU (master setup unit). Only one file can be stored, and will be stored in the camera and memory stick.

As for the items to be stored, refer to Section 5-8, “File Items”.

For reference files, differential data taking the factory-setting as 0 will be stored. Therefore, initializing the reference file brings the settings to the same status at factory-setting.^(*) Using the setting menu, all items or specified items can be initialized.

Reference files can be copied between cameras using the memory stick.

(*) : If lens files or OHB file retains the data, those need to be initialized as well.

Notes

- As for the setup menu, refer to Section 4.
- Before storing the file in the memory stick, make sure that the LOCK switch on the memory stick is in OFF position.

Storing Using the Setup Menu (Refer to step 1 of Fig.5-3.)

Set the setup menu as follows.

FILE → **REFERENCE** → **STORE FILE**

The data will be stored in the camera and the numerical data will be displayed as 0. (Excluding some items. Refer to Section 5-8. “File Items”.) If LOCK of the memory stick is set to OFF, the data will also be stored in the memory stick at the same time.

Storing by MSU (Refer to step 1 of Fig.5-3.)

Set the MODE switch to FILE and press **REFERENCE** and then press **REF STORE**. The data will be stored in the camera and the numerical data will be displayed as 0. (Excluding some items. Refer to Section 5-8. “File Items”.) If LOCK of the memory stick is set to OFF, the data will also be stored in the memory stick at the same time.

Calling Using the Setup Menu (Refer to step 2 of Fig. 5-3, Fig. 5-1.)

Set the setup menu as follows.

PAINT → **SCENE FILE** → **STANDARD**

The temporary paint amount and scene file amount will be cleared and the reference file will be reset to the state stored in.

Calling with MSU (Refer to step 2 of Fig. 5-3.)

Press the “STANDARD” switch to reset the reference file item to the state stored in.

Reading the Reference File from the Memory Stick (Refer to step 3 of Fig. 5-3.)

During the file storing, the reference files which have been stored in the memory stick at the same time are read and the reference files in the camera can also be changed.

Set the setup menu as follows.

FILE → **REFERENCE** → **READ (MS → CAM)**

After the data of the memory stick is read to the camera, STANDARD will be executed automatically.

Note

When the power is just turned on, the reference files stored in the memory stick will not be read. This file will only be read when READ is executed at the setup menu.

Storing the Reference File in the Memory Stick (Refer to step 1 of Fig. 5-3.)

The reference file stored in the camera unit is stored in the memory stick.

Set the setup menu as follows.

FILE → **REFERENCE** → **WRITE (CAM → MS)**

Initializing All File Items Using the Setup Menu (Refer to step 4 of Fig. 5-3.)

Set the setup menu as follows.

FILE → **FILE CLEAR** → **REFERENCE (ALL)**

Initializing Only Specified Items Using the Setup Menu (Refer to step 4 of Fig. 5-3.)

References files for specified items can be initialized using the setup menu.

(1) Set the setup menu as follows.

FILE → **FILE CLEAR** → **10 SEC CLEAR** → **ON**

(2) Move to the page containing the items to be initialized from the reference files in the setup menu.

(3) Adjust “→” to the item to be initialized using the rotary encoder, and keep pressing the rotary encoder about 10 seconds at “?” state until “REF CLEAR “ is displayed. About 3 seconds later, “DATA CLEAR” will be displayed at the bottom most line. The “REF CLEAR” is displayed about 10 seconds later, and the data will be initialized to 0.

Note

The 10 SEC CLEAR function must always be set to OFF when the power is turned ON.

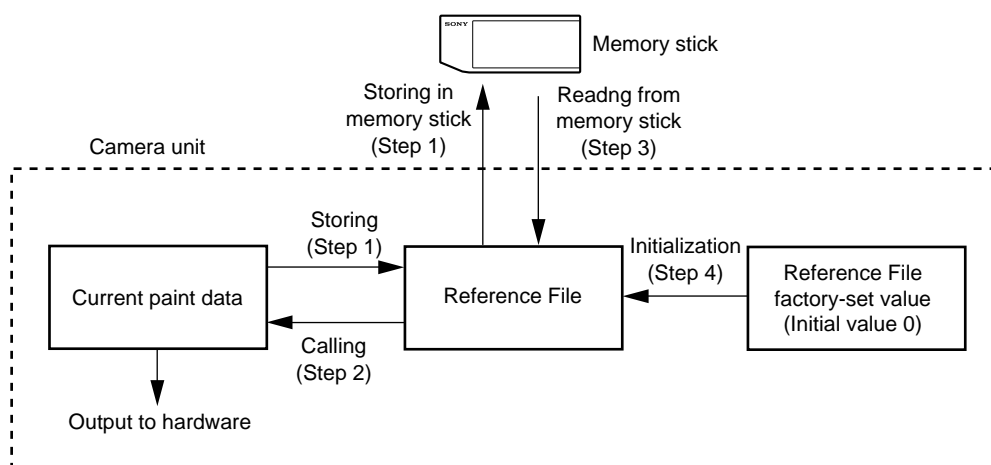

Fig. 5-3. Operating Procedure for Reference Files

5-6. Registering the Lens File

The white shading which occurs when the extender is turned on, flare balance, white balance, F value of the open edge of the lens, name, etc. can be stored. Up to 16 files can be stored. The adjustment data can be called by selecting the lens file. This data will be stored in the camera.

As for the items to be stored, refer to Section 5-8, "File Items".

The lens file stores the differential data from the reference file.

Notes

- Prior to creating the lens file, perform the necessary adjustments by using the lens normally used to create the reference file.
- As for the setup menu, refer to Section 4.

Adjusting the Lens File

- (1) Mount the lens. Select the file with the same name of the lens mounted from the setup menu.
If no file with the same lens name, select "NO OFFSET".
FILE → **LENS FILE** → **No.** → (Select the No.)
- (2) Set the lens file name and F value of the open edge of the lens.
- (3) With the lens extender set to OFF, adjust V modulation of R/G/B/Master. Shoot the all white pattern, set the iris F4 and zoom position to the center of the ring, and perform the adjustment around 560 mV of 80% video level. Also adjust the flare balance and white balance shooting the grayscale chart.
- (4) Store the data in the lens file. Set the setting menus as follows.
FILE → **LENS FILE** → **STORE FILE**
- (5) Set the extender to ON, adjust the V modulation of R/G/B/Master shooting the all white pattern, and adjust the flare balance and white balance shooting the grayscale chart.
- (6) Store the data in the lens file.
- (7) If the lens center deviates when the lens extender is switched to ON/OFF, store the center marker under the extender is ON state. Adjust **CENTER H POS** and **CENTER V POS** at the **LENS FILE** page, and execute **STORE CENTER**.

Note

The center marker will not be stored when the lens file is stored.

Calling the Lens File

Select the lens file set by the setup menu as follows.

OPERATION → **LENS FILE**

Initializing the Lens File

Set the setup menu as follows.

FILE → **FILE CLEAR** → **LENS (CURRENT)**

All data of the lens file being currently selected will be initialized to the factory setting values.

5-7. Registering the OHB File

The OHB file is used for storing the maintenance adjustment values of the CCD block and the data will be stored in the camera. The data can be stored using the setup menu or the MSU (master seup unit).

The items to be stored are the black shading, white shading, ND offset and OHB matrix.

Note

As for the setup menu, refer to Section 4.

5-7-1. Storing the Black Shading and White Shading

Storing Using the Setup Menu

(1) Execute the setup menu as follows.

FILE → **REFERENCE** → **STANDARD**

(2) Change the items to the desired value; H SAW, H PARA, V SAW and V PARA of each R/G/B for each of white shading and black shading.

(3) Set the setup menu as follows.

FILE → **OHB FILE** → **STORE FILE**

Storing with MSU

(1) Change the items to the desired value; H SAW, H PARA, V SAW, V PARA of each R/G/B for each of white shading and black shading.

(2) Press “STORE” of the OHB file.

5-7-2. Adjusting the ND Offset

The white balance may be slightly deviated in the ND filters. In such cases, adjust the offset. Taking the ND filter 1 white balance as the reference, the ND offset stores the deviation of the white balance of ND filter 2, 3, 4.

Adjusting the ND Offset

(1) Set the setup menu as follows.

FILE → **REFERENCE** → **STANDARD**

- (2) Connect the waveform monitor to MONITOR OUT connector of this unit.
(3) Select ND filter 4, and shoot the grayscale chart. Check that the illuminant condition is under that video level is within 560 mV thru. 630 mV. Then note the video level at this time.

Note

Do not adjust the ND offset if the video level is less than 560 mV.

- (4) Select 1 by the ND filter knob, and set the iris so that the video level is the same level as the noted video level of Step (2).
(5) Execute the auto white balance.
(6) Select 2 by the ND filter knob, and set the iris to meet the noted video level of Step (2).
(7) Execute the auto white balance.
(8) Select 3 by the ND filter knob, and set the iris to meet the noted video level of Step (2).
(9) Execute the auto white balance.
(10) Select 4 by the ND filter knob, and set the iris to meet the noted video level of Step (2).
(11) Execute the auto white balance.
(12) Store the ND offset.

Execute the setup menu as follows.

FILE → **OHB** → **STORE FILE**

Notes

- Adjust precisely to meet the noted video level, otherwise the deviation of the white balance of the ND filter may generate in some cases.
- If the level cannot be adjusted properly using the iris, adjust the level using the shutter/ECS or gain-up.

Calling the ND Offset

When the ND filter is changed, the ND offset will be called automatically.

Initializing the ND Offset

Execute the setup menu as follows.

FILE → **FILE CLEAR** → **OHB ND OFFSET**

5-8. File items

OPERATION menu

page	item	OPERATOR	REFERENCE	SCENE	OHB	LENS	STANDARD ^(#11)	Power is turned ON	Factory set
1	VF DISPLAY	●	–	–	–	–	–	–	(*10)
2	! IND	●	–	–	–	–	–	–	(*10)
3	MARKER	●	–	–	–	–	–	–	(*10)
4	GAIN SW L/M/H	●	–	–	–	–	–	–	0/6/12 dB
5	ZEBRA	●	–	–	–	–	–	–	(*10)
	VF DETAIL	●	–	–	–	–	–	–	0
6	AUTO IRIS WINDOW	●	–	–	–	–	–	–	1 ^(#9)
	OVERRIDE	–	–	–	–	–	–	–	0
7	BATT ALARM	●	–	–	–	–	–	–	(*15)
8	D5600K	–	●	●	–	–	REF	–	OFF
	ASSIGNABLE 1/2	●	–	–	–	–	–	–	OFF
9	LENS FILE NO.	–	–	–	–	–	–	–	1

PAINT menu

page	item	OPERATOR	REFERENCE	SCENE	OHB	LENS	STANDARD ^(#11)	Power is turned ON	Factory set
2	WHITE R/B	–	○	○	–	○ ^(#4)	REF ^(#8)	–	0
	WHITE G	–	○	○	–	–	REF	–	0
	BLACK R/G/B	–	–	○	–	–	0	–	0
	BLACK MASTER	–	○	○	–	–	REF	–	0
	FLARE R/G/B	–	○	○	–	○	REF	–	0
	FLARE SW	–	ON	●	–	–	ON	–	ON
	V MOD R/G/B	–	–	○	–	–	–	–	0
	V MOD MASTER	–	–	○	–	○	–	–	0
	V MOD SW	–	ON	–	–	–	ON	–	ON
3	GAMMA R/G/B	–	○	○	–	–	REF	–	0
	GAMMA MASTER	–	○	○	–	–	REF	–	0
	GAMMA COARSE	–	●	●	–	–	REF	–	0.45
	GAMMA TABLE	–	●	●	–	–	REF	–	STANDARD2
	GAMMA SW	–	ON	●	–	–	ON	–	ON
4	BLK GAMMA R/G/B	–	○	○	–	–	REF	–	0
	BLK GAMMA MASTER	–	○	○	–	–	REF	–	0
	BLK GAMMA RGB RANGE	–	●	●	–	–	REF	–	15 %
	BLK GAMMA RGB SW	–	●	●	–	–	REF	–	OFF
	BLK GAMMA Y	–	○	○	–	–	REF	–	0
	BLK GAMMA Y RANGE	–	●	●	–	–	REF	–	15 %
	BLK GAMMA Y SW	–	●	●	–	–	REF	–	OFF

page	item	OPERATOR	REFERENCE	SCENE	OHB	LENS	STANDARD ^{(*)1}	Power is turned ON	Factory set
5	LOW KEY SAT	–	○	○	–	–	REF	–	0
	BLK CLIP	–	○	○	–	–	REF	–	0
	LOW KEY SAT SW	–	●	●	–	–	REF	–	OFF
6	KNEE POINT R/G/B	–	○	○	–	–	REF	–	0
	KNEE POINT MASTER	–	○	○	–	–	REF	–	0
	KNEE SLOPE R/G/B	–	○	○	–	–	REF	–	0
	KNEE SLOPE MASTER	–	○	○	–	–	REF	–	0
	KNEE SW	–	●	●	–	–	REF	–	ON
	WHITE CLIP R/G/B	–	○	○	–	–	REF	–	0
	WHITE CLIP MASTER	–	○	○	–	–	REF	–	0
	WHITE CLIP SW	–	ON	●	–	–	REF	ON	ON
	KNEE SAT LEVEL	–	○	○	–	–	REF	–	0
	KNEE SAT SW	–	●	●	–	–	REF	–	OFF
	7	DETAIL LEVEL	–	○	○	–	–	REF	–
DETAIL SW		–	ON	●	–	–	REF	–	ON
DETAIL WHITE LIMITER		–	○	○	–	–	REF	–	0
DETAIL BLACK LIMITER		–	○	○	–	–	REF	–	0
DETAIL LIMITER MASTER		–	○	○	–	–	REF	–	0
DETAIL CRISP		–	○	○	–	–	REF	–	0
DETAIL H/V RATIO		–	○	○	–	–	REF	–	0
DETAIL H FREQ		–	○	○	–	–	REF	–	0
DETAIL LEVEL DEPEND		–	○	○	–	–	REF	–	0
DETAIL LEVEL DEP SW		–	●	●	–	–	REF	–	OFF
8		FINE DETAIL	–	○	○	–	–	REF	–
	FINE DETAIL SW	–	●	●	–	–	REF	–	OFF
	KNEE APERTURE	–	○	○	–	–	REF	–	0
	KNEE APT SW	–	●	●	–	–	REF	–	OFF
9	SKIN DETAIL LEVEL	–	○	○	–	–	REF	–	0
	SKIN DETAIL PHASE 1/2/3	–	◎	◎	–	–	REF	–	0°
	SKIN DETAIL WIDTH 1/2/3	–	◎	◎	–	–	REF	–	30°
	SKIN DETAIL SAT 1/2/3	–	◎	◎	–	–	REF	–	–89
	SKIN DETAIL CH–1 SW	–	ON	●	–	–	ON	–	ON
	SKIN DETAIL CH–2,3 SW	–	●	●	–	–	REF	–	OFF
	SKIN DETAIL GATE SW	–	–	–	–	–	–	OFF	OFF
	SKIN DETAIL GATE 1 SW	–	ON ^{(*)1}	–	–	–	ON	–	ON
	SKIN DETAIL GATE 2/3 SW	–	OFF ^{(*)1}	–	–	–	OFF	–	OFF
10	USER MATRIX	–	◎	◎	–	–	REF	–	0
	USER MATRIX SW	–	●	●	–	–	REF	–	OFF
	PRESET MATRIX SEL	–	●	●	–	–	REF	–	SMPTE-240M
	PRESET MATRIX SW	–	●	●	–	–	REF	–	OFF
	MATRIX SW	–	●	●	–	–	REF	–	OFF

page	item	OPERATOR	REFERENCE	SCENE	OHB	LENS	STANDARD ^(#11)	Power is turned ON	Factory set
11	MULTI MATRIX PHASE	–	–	–	–	–	–	–	0
	MULTI MATRIX HUE	–	⊙	⊙	–	–	REF	–	0
	MULTI MATRIX SAT	–	⊙	⊙	–	–	REF	–	0
	MULTI MATRIX SW	–	●	●	–	–	REF	–	OFF
12	SHUTTER SEL	–	●	●	–	–	REF	–	1/100
	SHUTTER SW	–	●	●	–	–	REF	– ^(#5)	OFF
	ECS SW	–	●	●	–	–	REF	– ^(#5)	OFF
	ECS FREQ	–	⊙	⊙	–	–	REF	–	24 Hz
	S-EVS (%)	–	⊙	⊙	–	–	REF	–	0
	S-EVS SW	–	●	●	–	–	REF	–	OFF
	TEST 1	–	–	–	–	–	–	OFF	OFF
TEST 2	–	–	–	–	–	–	OFF	OFF	

MAINTENANCE menu

page	item	OPERATOR	REFERENCE	SCENE	OHB	LENS	STANDARD ^(#11)	Power is turned ON	Factory set
2	WHITE SHADING VSAW R/G/B	–	–	–	○	–	OHB	–	0
	WHITE SHADING V PARA R/G/B	–	–	–	○	–	OHB	–	0
	WHITE SHADING HSAW R/G/B	–	–	–	○	–	OHB	–	0
	WHITE SHADING H PARA R/G/B	–	–	–	○	–	OHB	–	0
3	BLACK SHADING VSAW R/G/B	–	–	–	○	–	OHB	–	0
	BLACK SHADING V PARA R/G/B	–	–	–	○	–	OHB	–	0
	BLACK SHADING HSAW R/G/B	–	–	–	○	–	OHB	–	0
	BLACK SHADING H PARA R/G/B	–	–	–	○	–	OHB	–	0
	BLACK SET R/G/B	–	–	–	–	–	–	–	0
	MASTER GAIN	–	●	●	–	–	REF	– ^(#5)	0 dB
4	OHB MULTI MATRIX PHASE	–	–	–	–	–	–	–	0
	OHB MULTI MATRIX HUE	–	–	–	○	–	OHB	–	0
	OHB MULTI MATRIX SAT	–	–	–	○	–	OHB	–	0
	OHB MULTI MATRIX SW	–	–	–	–	–	–	–	OFF
5	AUTO IRIS LEVEL	–	⊙	⊙	–	–	REF	–	0
	AUTO IRIS APL RATIO	–	⊙	–	–	–	REF	–	82
	AUTO IRIS GAIN	–	⊙	–	–	–	REF	–	0
6	CAMERA ID	–	–	–	–	–	–	–	–
7	MULTI FORMAT	–	–	–	–	–	–	–	23.98PsF
8	VTR SETUP	–	–	–	–	–	–	–	^(#10)
9	BATT ALARM	–	–	–	–	–	–	–	^(#10)

page	item	OPERATOR	REFERENCE	SCENE	OHB	LENS	STANDARD ^(※11)	Power is turned ON	Factory set
10	H PHASE	—	—	—	—	—	—	—	0
	MONITOR OUT Y, Pb/Pr	—	—	—	—	—	—	—	0
11	FAN MODE	—	●	●	—	—	REF	—	AUTO1
	MENU RESUME	—	—	—	—	—	—	—	OPE MENU
	DATE TYPE	—	—	—	—	—	—	—	Y/Mn/D
	WHITE MEMORY	—	—	—	—	—	—	—	8
	TEST 1	—	—	—	—	—	—	OFF	OFF
	TEST 2	—	—	—	—	—	—	OFF	OFF

FILE menu

page	item	OPERATOR	REFERENCE	SCENE	OHB	LENS	STANDARD ^(※11)	Power is turned ON	Factory set
4	LENS FILE NAME	—	—	—	—	●	—	—	1
	LENS FILE IRIS F NO.	—	—	—	—	●	—	—	F2.0
	LENS FILE CENTER MARKER H	—	—	—	—	●	—	—	0
	LENS FILE CENTER MARKER V	—	—	—	—	●	—	—	0
6	REFERENCE 10 SEC CLEAR	—	—	—	—	—	—	OFF	OFF

External switches

item	OPERATOR	REFERENCE	SCENE	OHB	LENS	STANDARD ^(※11)	Power is turned ON	Factory set
ND FILTER	—	—	● ^(※2)	—	—	—	—	ND1
ND OFFSET	—	—	—	○	—	—	—	0
CC FILTER	—	—	● ^(※2)	—	—	—	—	CCB
AUTO KNE (DCC)	—	●	●	—	—	REF	— ^(※5)	OFF
CHU COLOR BAR	—	—	—	—	—	—	— ^(※5)	OFF
WHITE MEMORY PRESET A, B	—	—	—	—	—	—	— ^(※6)	B

Others

item	OPERATOR	REFERENCE	SCENE	OHB	LENS	STANDARD ^(※11)	Power is turned ON	Factory set
AUTO IRIS	—	—	●	—	—	—	ON ^(※3)	ON
IRIS CLOSE	—	—	—	—	—	—	OFF ^(※3)	OFF
DIGITAL GAIN ^(※7)	—	●	●	—	—	REF	—	OFF

MSU connected only

item	OPERATOR	REFERENCE	SCENE	OHB	LENS	STANDARD ^{(*)11}	Power is turned ON	Factory set
V DTL CREATION MODE	–	●	●	–	–	REF	–	MAX
V DTL CONTROL MODE	–	●	–	–	–	REF	–	ON
KNEE MAX	–	OFF	●	–	–	OFF	OFF	OFF
AUTO KNEE POINT	–	●	–	–	–	REF	–	0
WHITE SETUP MODE	–	–	–	–	–	–	–	AWB

◎ shows an analog item which will not be indicated as 0 after being stored.

○ shows an analog item which will be indicated as 0 after being stored.

● shows a switch which will be stored in the select item.

REF returns the status to the one when stored in the reference file.

OHB returns the status to the one when stored in the OHB file.

If mentioned as ON or OFF, the values will be same as ON or OFF.

If mentioned as –, the value does not change.

(*1): In SKIN DETAIL GATE 1/2/3, one among 1, 2 and 3 is to be set ON.

(*2): When using an electromotive filter

(*3): Only when using standalone

(*4): WHITE value stored is used when the extender ON.





(*5): The state depends on the one of the external switch when the standalone state.

(*6): When connecting to the MSU (master setup unit), the memory enters the temporally released state. As PRESET brings WHITE R/G/B to 0, regardless of the factory setting value of 3200K, if changing WHITE R/G/B and performing REFERECE STORE, the specified value is recalled as PRESET.

(*7): DIGITAL GAIN state is stored when being allocated to ASSIGNABLE 1 or 2.

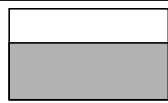
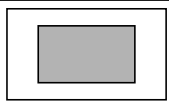
(*8): When WHITE SETUP MODE setting is ABW, the value when selecting AWB is returned and when selecting AUTO LEVEL, 0 is returned.

(*9):

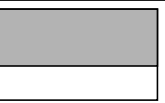
Setting	1	2	3	4	5	6
VF screen						

 indicates the auto iris window frame.

(*10): Refer to Section 4, “Setup Menu”.

(*11): Shows items to be called when **STANDARD** is executed, that is the reference file is called.

Section 6

Periodic Maintenance and Inspection

6-1. Cleaning

Make it a rule to clean the unit periodically to assure that the unit functions and performs at its best for the longest-possible product-life period.

6-1-1. General Information on Cleaning

1. Index

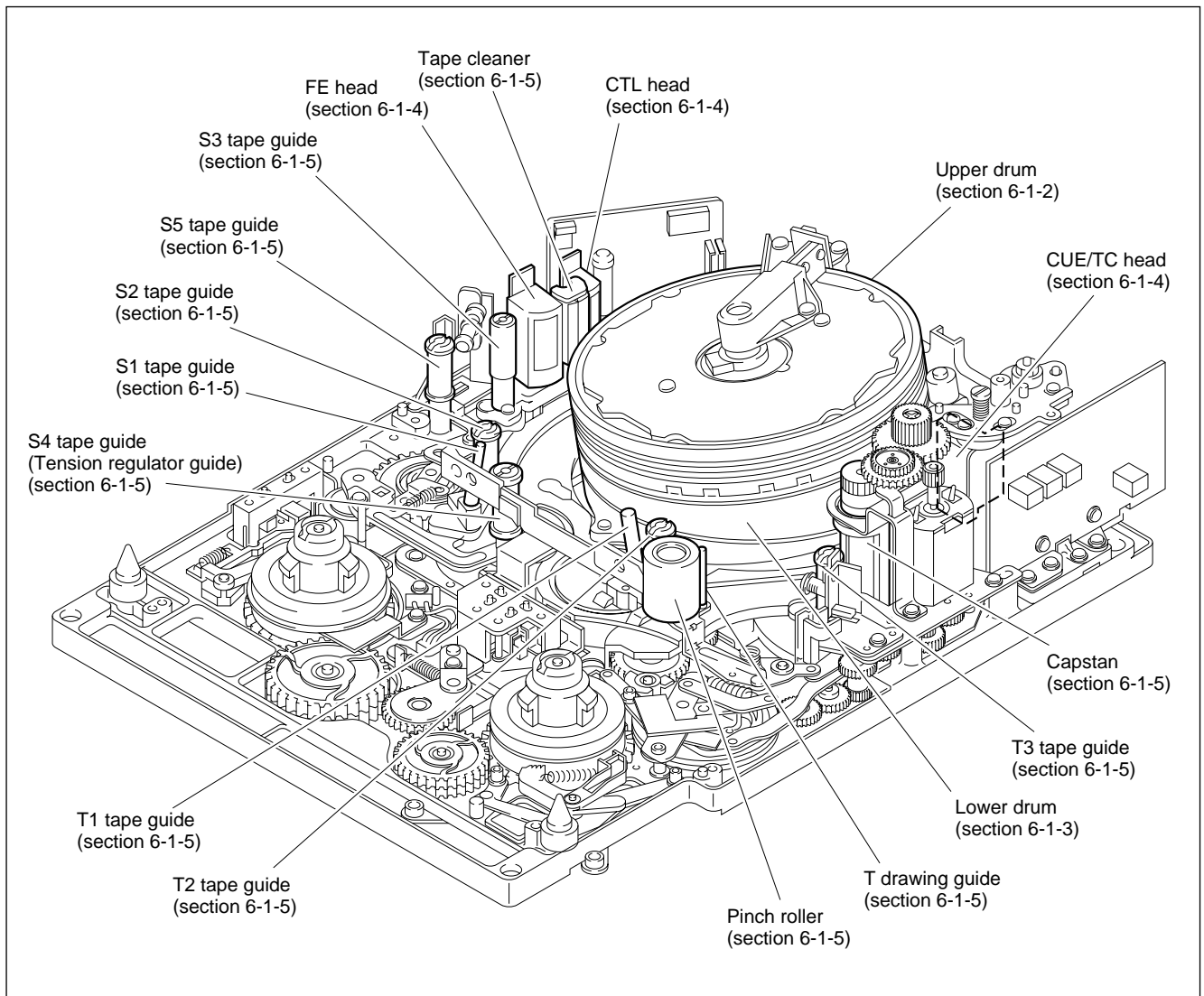

2. Notes

- Be sure to turn the power off before cleaning.
- The mechanical deck blocks consist of precision parts, and are fabricated and adjusted precisely. Do not damage the parts nor apply excessive force during cleaning.
- Do not touch the greased areas during cleaning. If grease adheres to a cleaning cloth, replace the cleaning cloth with a new one. If a cleaning cloth smeared with grease is used, the grease may adhere to the areas which should not be greased.
- Do not insert a cassette tape before the cleaning fluid evaporates completely.

3. Preparations

Remove the front lid and outside panel. (Refer to section 2-4.)

4. Cleaning Cassette Tape

Make sure to use the specified cleaning cassette tape.

Specified cleaning cassette tape : BCT-HD12CL

For details, refer to Operation Manual.

6-1-2. Cleaning of Tape Running Surface of Upper Drum and Video Heads

Note

The video head and upper drum may damage easily. Be careful not to damage them when cleaning.

Tools

- Cleaning cloth : 3-184-527-01
- Cleaning fluid : 9-919-573-01

Note

Never use a cotton swab.

Procedure

1. Apply a cleaning cloth moistened with cleaning fluid to the video heads, and rotate the upper drum slowly counterclockwise by fingers.
2. Apply a cleaning cloth moistened with cleaning fluid to the tape running surface of the upper drum (shaded portion) as shown, and clean it along the outer surface.

Notes

Be sure to rotate the upper drum counterclockwise. Be sure to clean the surface along the outer circumference. (Do not clean the surface in the vertical direction. This may damage the heads.)

3. After cleaning, wipe off moisture using a dry cleaning cloth.

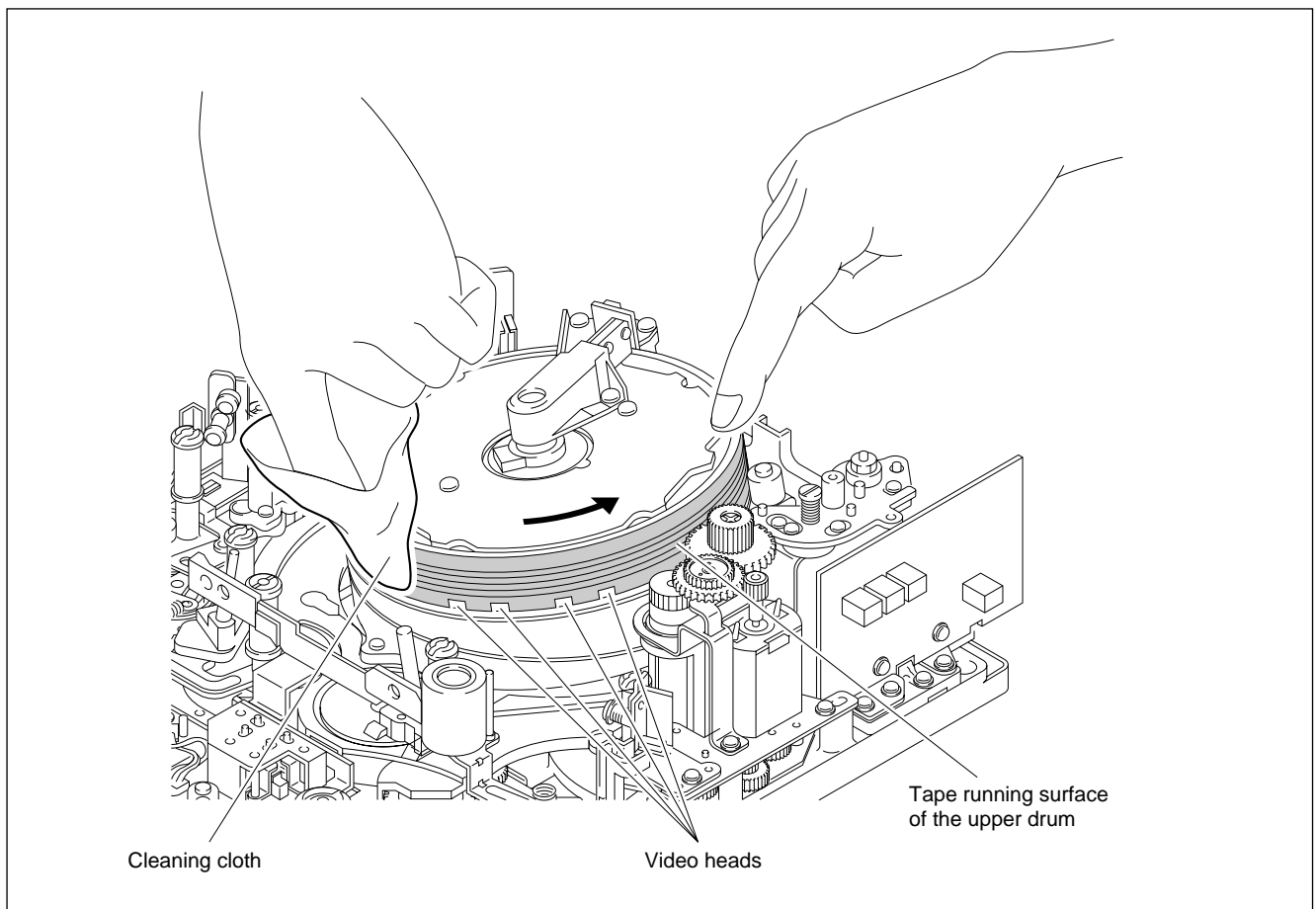

6-1-3. Cleaning of Tape Running Surface of Lower Drum and Lead Surface

Note

Be careful not to damage the lower drum (especially the lead surface) when cleaning.
Also clean the upper edges of the lower drum carefully because they are near the video heads.

Tools

- Cleaning cloth : 3-184-527-01
- Cleaning fluid : 9-919-573-01
- Wooden stick or equivalent (Metal pick cannot be used)

Procedure

1. Move a wooden stick (or equivalent) along the drum lead surface and remove magnetic particles as shown in the figure.

Notes

- (1) Do not use a metal stick in place of a wooden stick because it may damage the tape running surface.
 - (2) Remove magnetic particles completely from the drum lead surface. Otherwise, they may affect tracking.
2. Clean the tape running surface of the lower drum and lead surface (shaded portion) using a cleaning cloth moistened with cleaning fluid.
 3. After cleaning, be sure to wipe off moisture using a dry cleaning cloth.

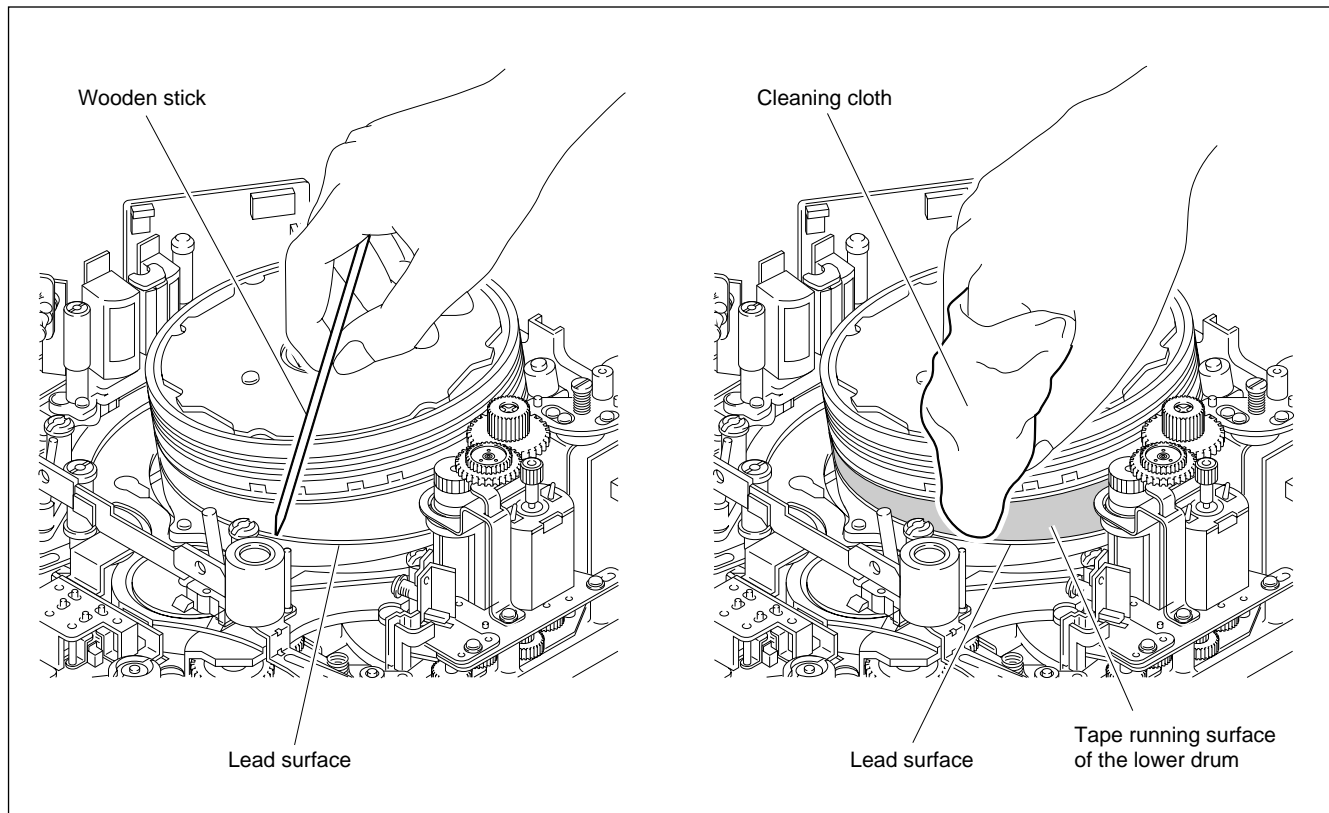

6-1-4. Cleaning of Stationary Heads

Note

Be careful not to damage the surfaces of the stationary heads when cleaning.

Tools

- Cleaning cloth : 3-184-527-01
- Cleaning fluid : 9-919-573-01

Procedure

1. Clean the tape running surfaces (shaded portion) of the FE, CTL, CUE/TC heads by wiping them in the vertical direction using a cleaning cloth moistened with cleaning fluid.

Note

Remove magnetic particles completely from the head gaps of the FE, CTL and CUE/TC heads. Otherwise, they may cause recording and playback errors.

2. After cleaning, be sure to wipe off moisture using a dry cleaning cloth.

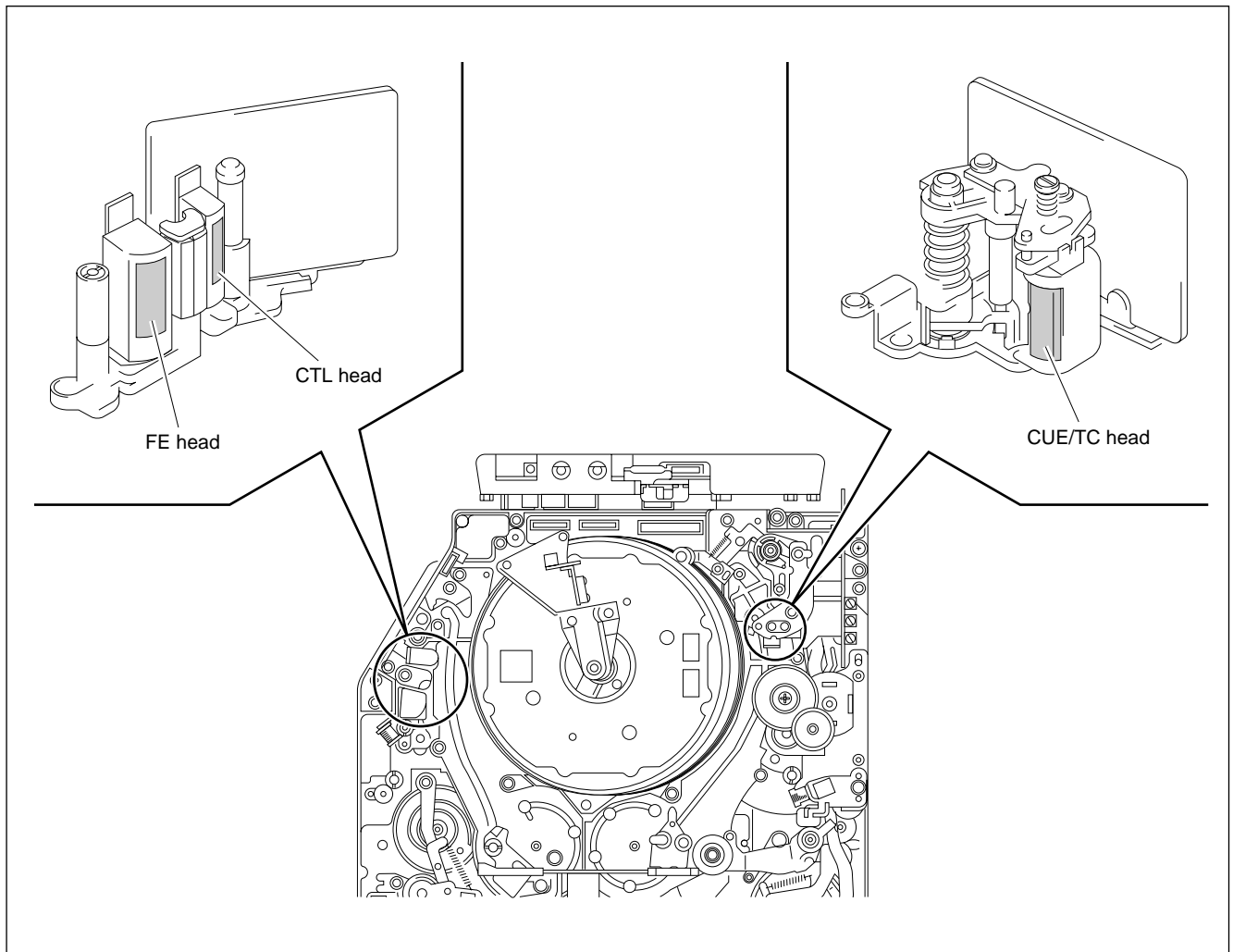

6-1-5. Cleaning of Tape Path System and Tape Cleaner

CAUTION

The edge of the tape cleaner is very sharp and may hurt your fingers. Avoid touching the edge when cleaning.

Tools

- Cleaning cloth : 3-184-527-01
- Cleaning fluid : 9-919-573-01

Procedure

1. Clean the tape running surfaces (shaded portions) of the following guides and the edge of the tape cleaner using a cleaning cloth moistened with cleaning fluid.

S1 to S5 guides, T1 to T3 guides, T drawer guide, capstan, pinch roller

CAUTION

Never touch the edge of the tape cleaner.

2. Remove the magnetic particles left in the gaps of the tape cleaner with paper, etc.
3. After cleaning, be sure to wipe off moisture using a dry cleaning cloth.

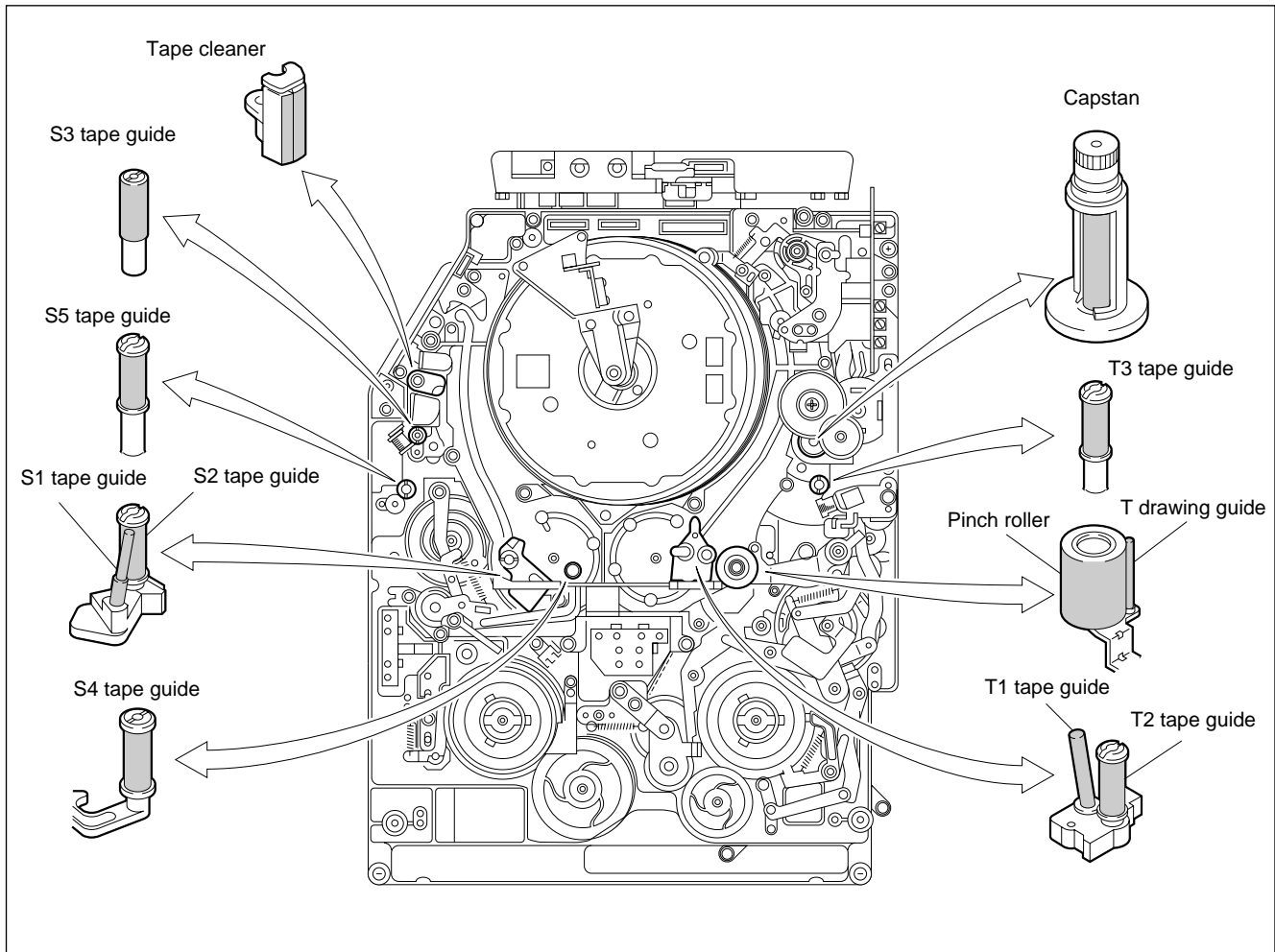

6-1-6. Cleaning of Filter

Clean the dust-filter periodically once every 2 or 3 months. Otherwise, clogging of dusts, etc. may cause the temperature inside the unit to rise and result in malfunctions.

Removal

1. Remove the four precision screws (P2 × 5, P2 × 10) and remove covers.
2. Remove the three filters.

Cleaning

Wash the filters by hands with neutral detergent and leave them in the shade to dry.

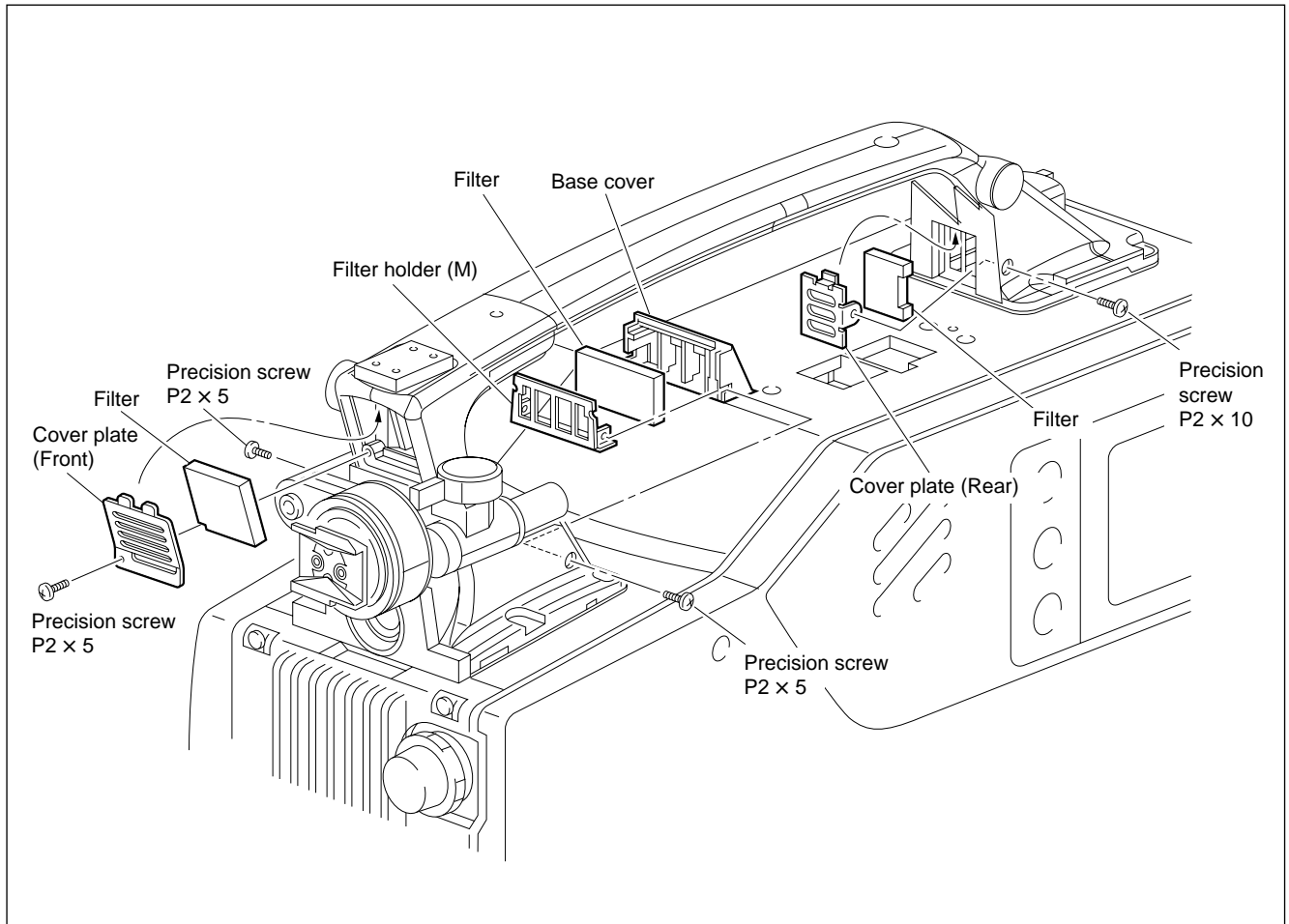

6-2. Maintenance After Use in Special Environments

It is recommended that the following be checked after use in special environments such as seaside, dusty places, hot springs.

1. Remove the sand and dusts from the unit thoroughly.
2. Clean off the salt from seawater and sulfur from hot springs.
3. Clean the video head, upper and lower drums, and stationary heads.
4. Clean the tape running surface (tape guide, capstan shaft, pinch roller, etc.).
5. Clean the connector pin of the connector panel.
6. Perform general operations (recording, playback, etc.) and verify that no abnormal noises are produced from the unit and that the unit operates normally.

If operations are found abnormal, etc., please contact Sony Sales Office/Service Center.

6-3. Periodic Inspections

Make it a rule to carry out periodic inspections to assure that the unit functions and performs at its best for the longest-possible product-life period.

6-3-1. Hours Meter

The unit can display a hours meter on its LCD display at the side panel. The hours meter is resetable. It is recommended that periodic inspection be carried out using this hours meter.

1. Displaying

- (1) Press the “DIAGNOSTIC” switch on the side panel using a stick tip to enter the DIAGNOSTIC mode.
- (2) To shift the menu, press the ADVANCE or SHIFT button on the side panel.
 ADVANCE button : Shifts the left digit one step at a time.
 SHIFT button : Shifts the right digit one step at a time.
- (3) To end the DIAGNOSTIC mode, press the “DIAGNOSTIC” switch again.

2. Display Screen

MODE	DESCRIPTION
LCD SCREEN	
HOURS METER	The following are displayed.
	1. Drum running meter (Cumulative)
	2. Tape running meter (Cumulative)
	3. Operation meter (Cumulative)
	4. Threading counter (Cumulative)
	5. Drum running meter (Resetable)
	6. Tape running meter (Resetable)
	7. Operation meter (Resetable)
	8. Threading counter (Resetable)

6-3-2. Periodic Inspection List

Note

The parts with the marking “↓” (① to ③) are included in the part listed immediately below (④).

MODE A : DRUM RUNNING METER

MODE B : TAPE RUNNING METER

◇ : Check ☆ : Replacement

No.	Item	MODE	Inspection Hours (H)								Replacement Part		
			500	1000	1500	2000	2500	3000	3500	4000	Part Discription	Part No.	Qty.
①	Upper drum assembly	A	☆	☆	☆	☆	☆	↓	☆	☆	Upper drum assembly (DHR-04-R)	A-8316-738-	1
②	Brush assembly for slip ring	A	—	☆	—	☆	—	↓	—	☆	Brush assembly (RP)	A-8263-856-	1
③	Slip ring assembly	A	—	☆	—	☆	—	↓	—	☆	Slip ring assembly (RP)	A-8263-855-	1
④	Drum assembly	A	—	—	—	—	—	☆	—	—	Drum assembly (DHH-04A-R)	A-8316-736-	1
⑤	Drum assembly	B	☆	☆	☆	☆	☆	☆	☆	☆	Pinch roller	X-3678-926-	1
⑥	HC roller for video head	A	☆	☆	☆	☆	☆	☆	☆	☆	AHC roller assembly	X-3949-109-	1
⑦	Cleaning brush for CUE head	A	—	☆	—	☆	—	☆	—	☆	CUE brush	3-681-778-	1
⑧	Tension regulator assembly	B	—	☆	—	☆	—	☆	—	☆	Tension regulator band assembly	X-3678-114-	1
⑨	T soft brake assembly	B	—	☆	—	☆	—	☆	—	☆	T soft brake assembly	X-3678-096-	1
⑩	S idler assembly	B	—	☆	—	☆	—	☆	—	☆	S idler assembly	A-8278-249-	1
⑪	T idler assembly	B	—	☆	—	☆	—	☆	—	☆	T idler assembly	A-8278-352-	1
⑫	Swing gear assembly	B	—	☆	—	☆	—	☆	—	☆	Gear assembly	A-8278-034-	1
⑬	Timing belt	B	—	—	—	—	—	☆	—	—	Timing belt	3-679-723-	1
⑭	Capstan motor	B	—	—	—	—	—	☆	—	—	DC motor SCV-0702A	8-835-534-01	1
⑮	CTL head	B	—	—	—	—	—	☆	—	—	CTL head PS244-21D	8-825-779-72	1
⑯	CUE head	B	—	—	—	—	—	☆	—	—	AU head PS244-2103L	8-825-779-61	1
⑰	Cassette compartment	B	—	—	—	—	—	☆	—	—	Cassette compartment (RP)	A-8318-064-	1

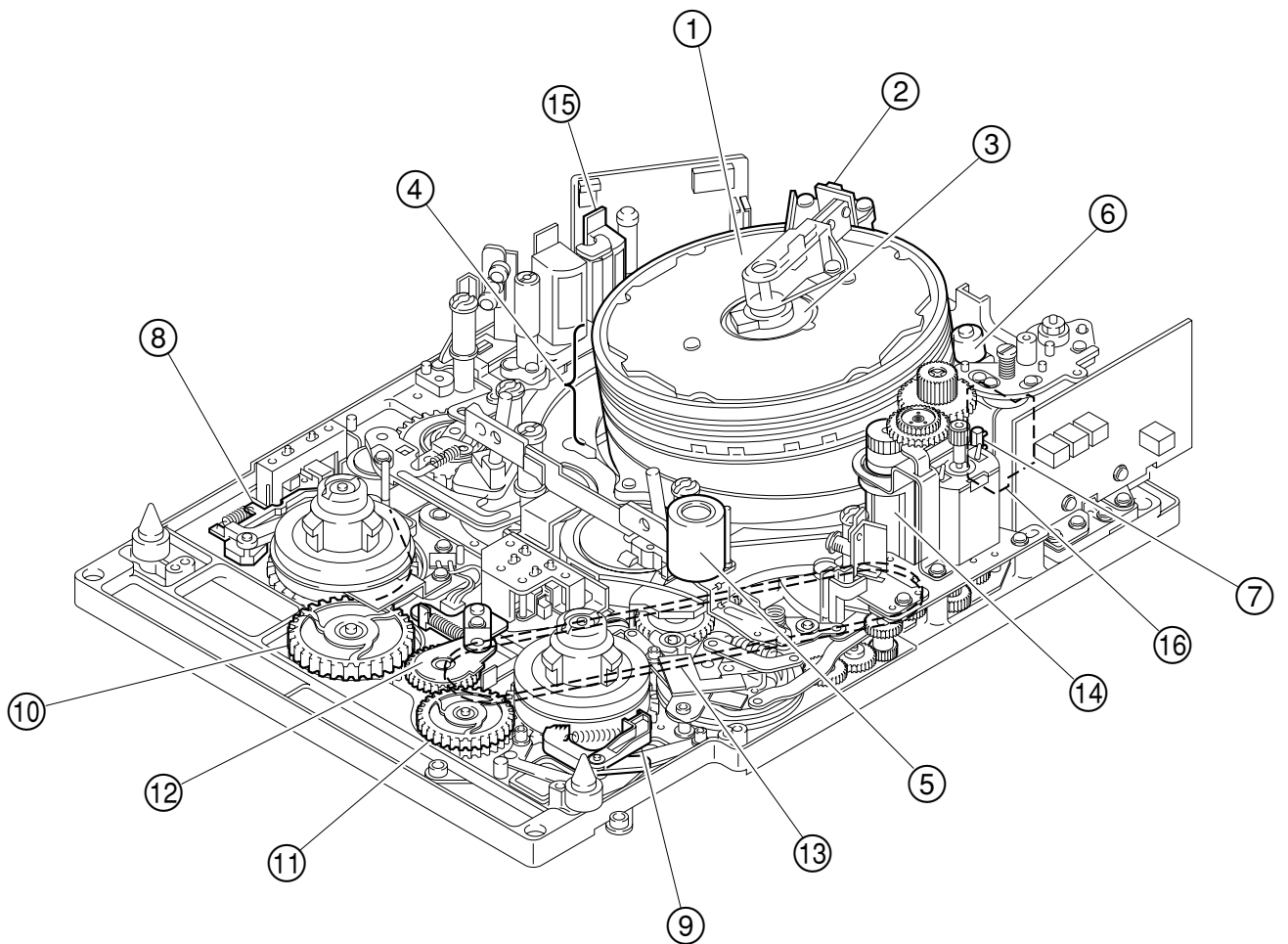
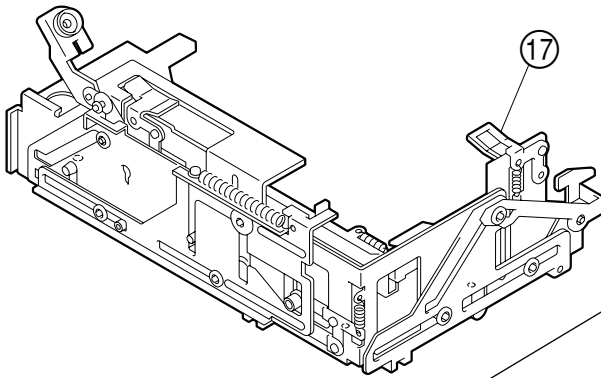

6-3-3. Recommended Replacing Parts

Following parts are recommended replacing parts. The optical filter unit may become cloudy with the lapse of time. By such a cloudy optical filter unit, the characteristics of this camera could not fully exploited, therefore replace it if necessary. Besides, the parts made of rubber used for the cabinet of this camera and the viewfinder may become cracked and split with the lapse of time, therefore also replace it if necessary.

No.	Part Description	Sony Part No.	Reference
–	FAN ASSY, FRONT *1	A-8278-742-	Replacement in every two years (Rotates whenever the unit is activated)
–	FAN ASSY, REAR *1	A-8325-881-	Replacement in every four years (Rotates during playback)
①	FILTER UNIT, OPTICAL	1-758-483-1X	
②	CAP (A), BNC	3-610-575-0X	rubber part
③	CAP (B), BNC	3-610-576-0X	rubber part
④	RUBBER (G-1N), DROP PROTECTION	3-610-515-0X	rubber part
⑤	PAD ASSY SHOLDER	A-8278-288-	rubber part
⑥	MIC CUSHION, RUBBER *2	3-692-138-0X	rubber part
⑦	EYE, CUP	3-723-079-0X	rubber part
–	LITHIUM BATTERY	1-767-156-11	Replacement in every five years On the IC505 in the APR-55 board
–	SPACER, MICROPHONE	3-179-882-0X	
–	HOLDER (B), MICROPHONE	3-680-582-0X	

*1: Refer to the maintenace manual part 2 Vol. 1 for details on replacement.

*2: It is recommendable to replace rubbers at upper and lower sides in a pair, so that order two pieces at replacing.

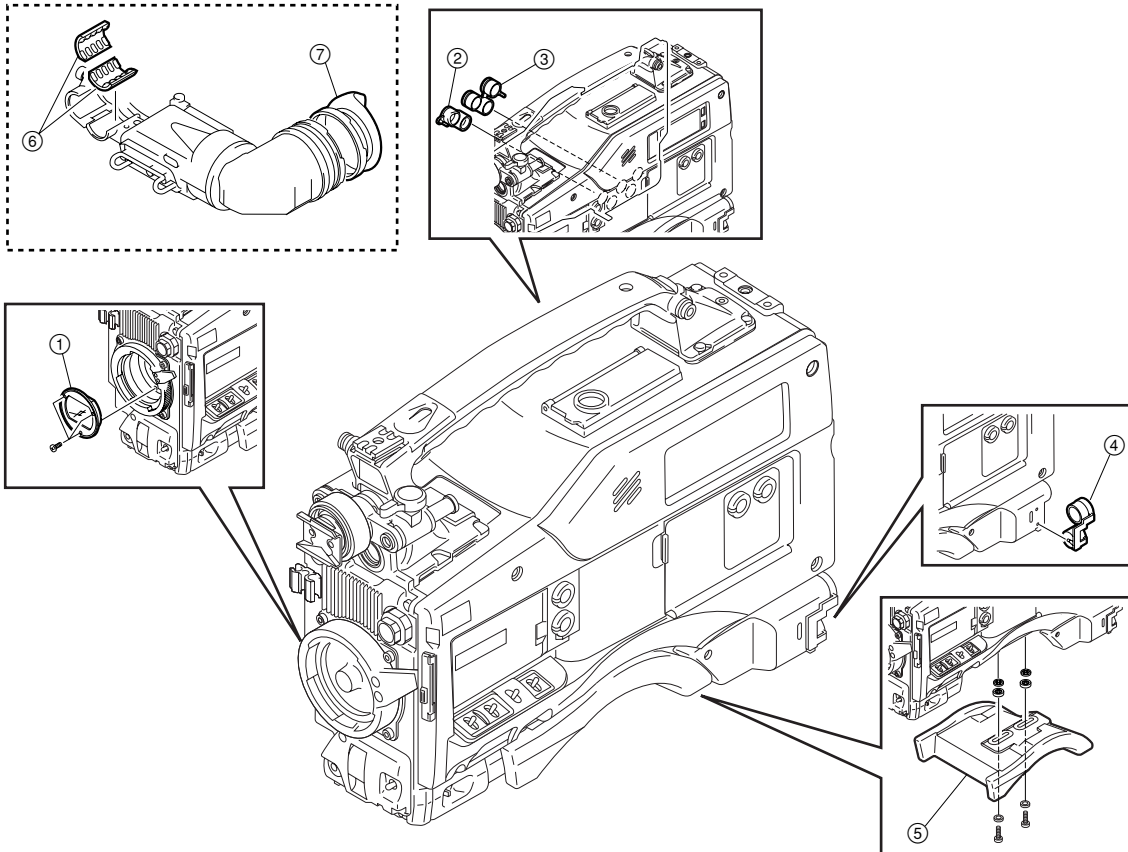

Section 7 Overall Block Diagrams

7-1. Camera Block

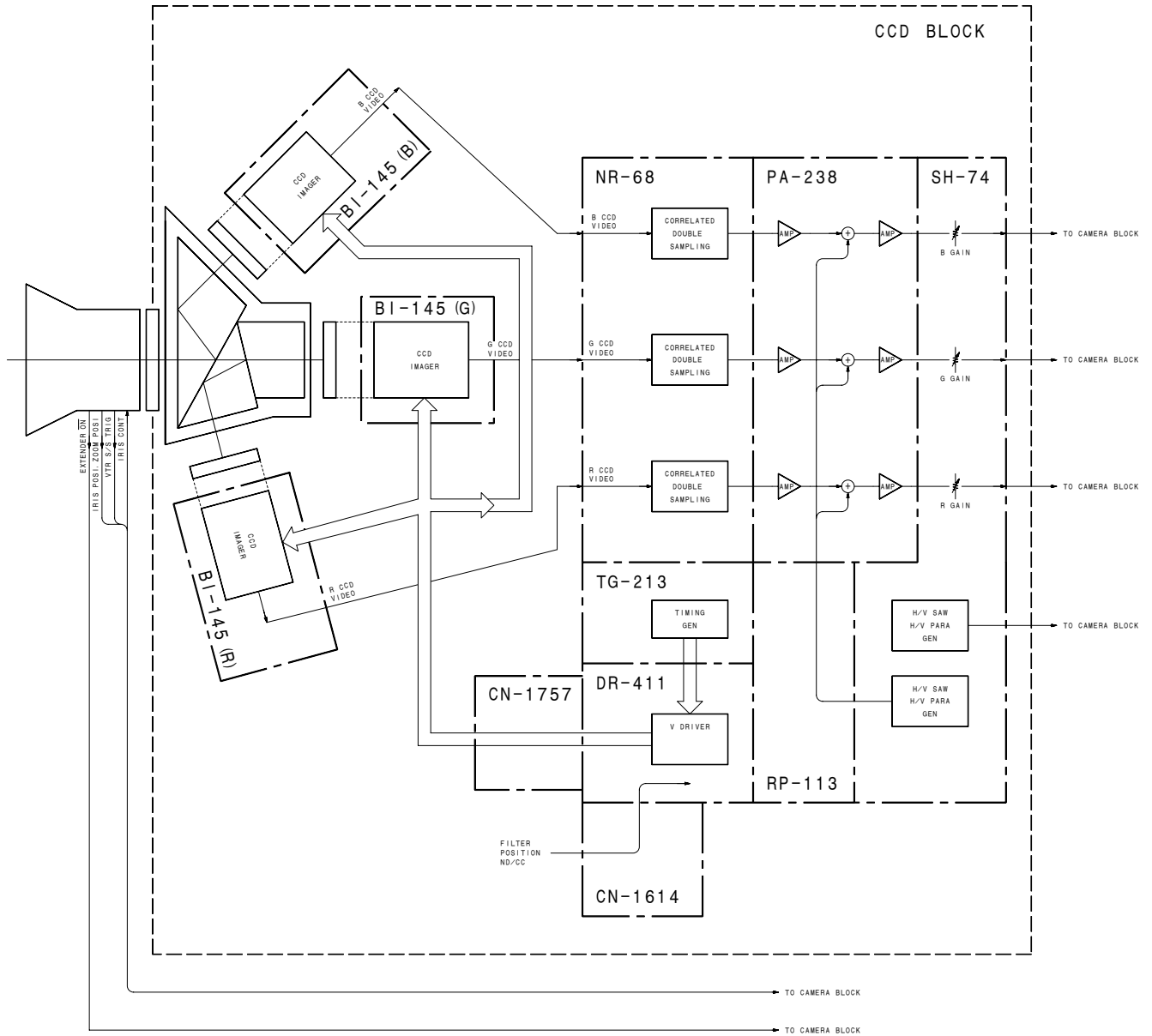

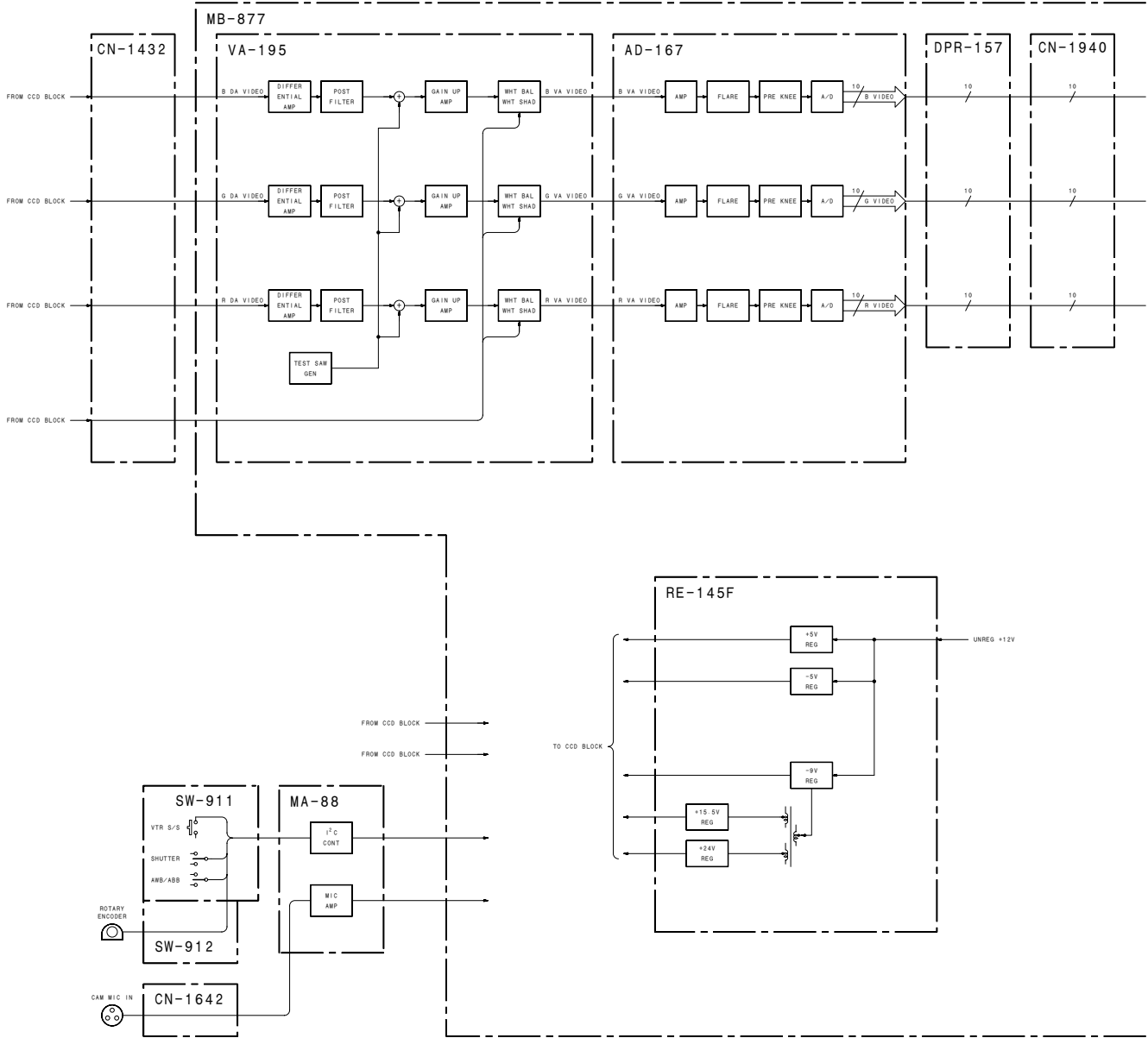

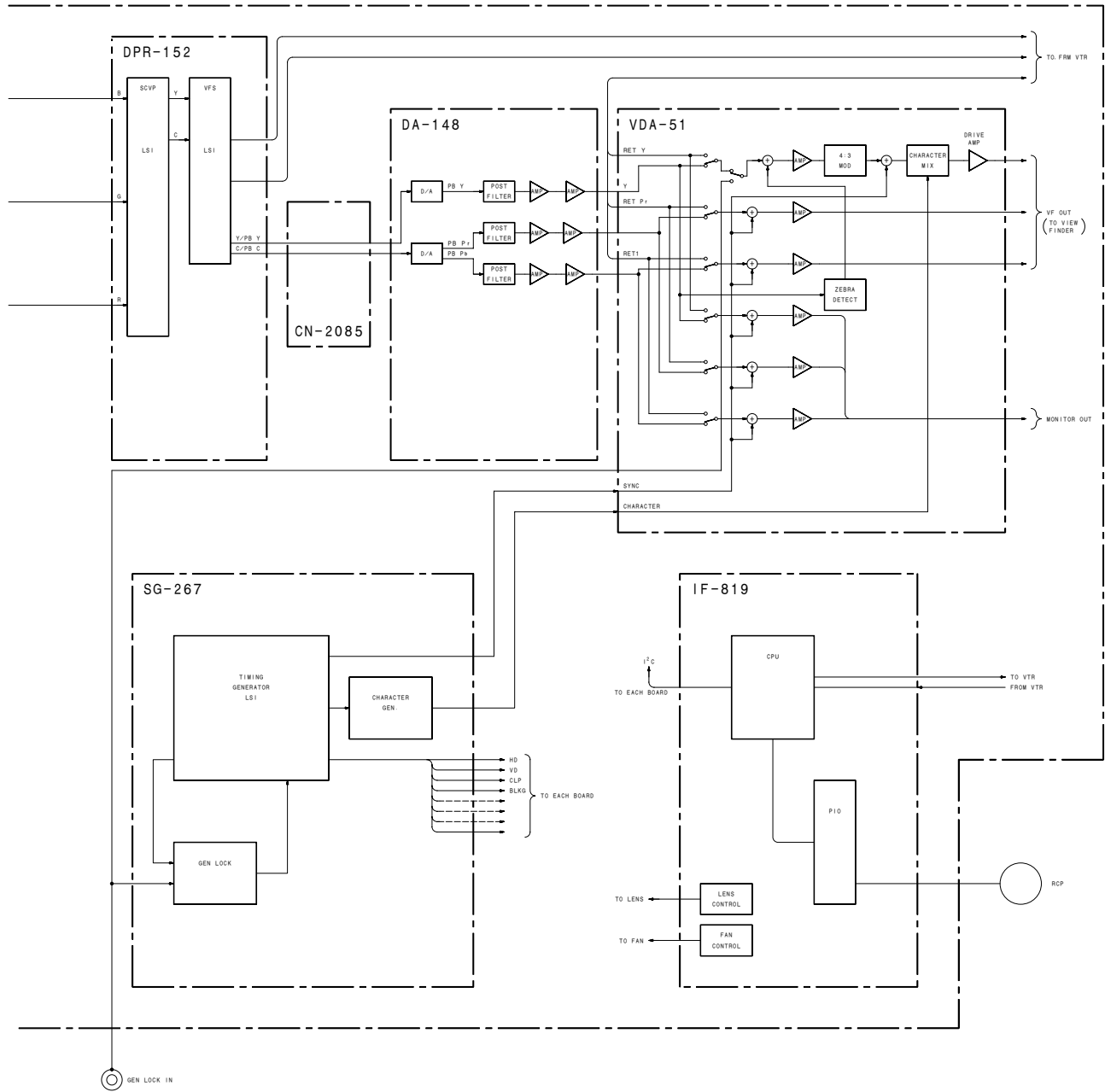

7-2. VTR Block

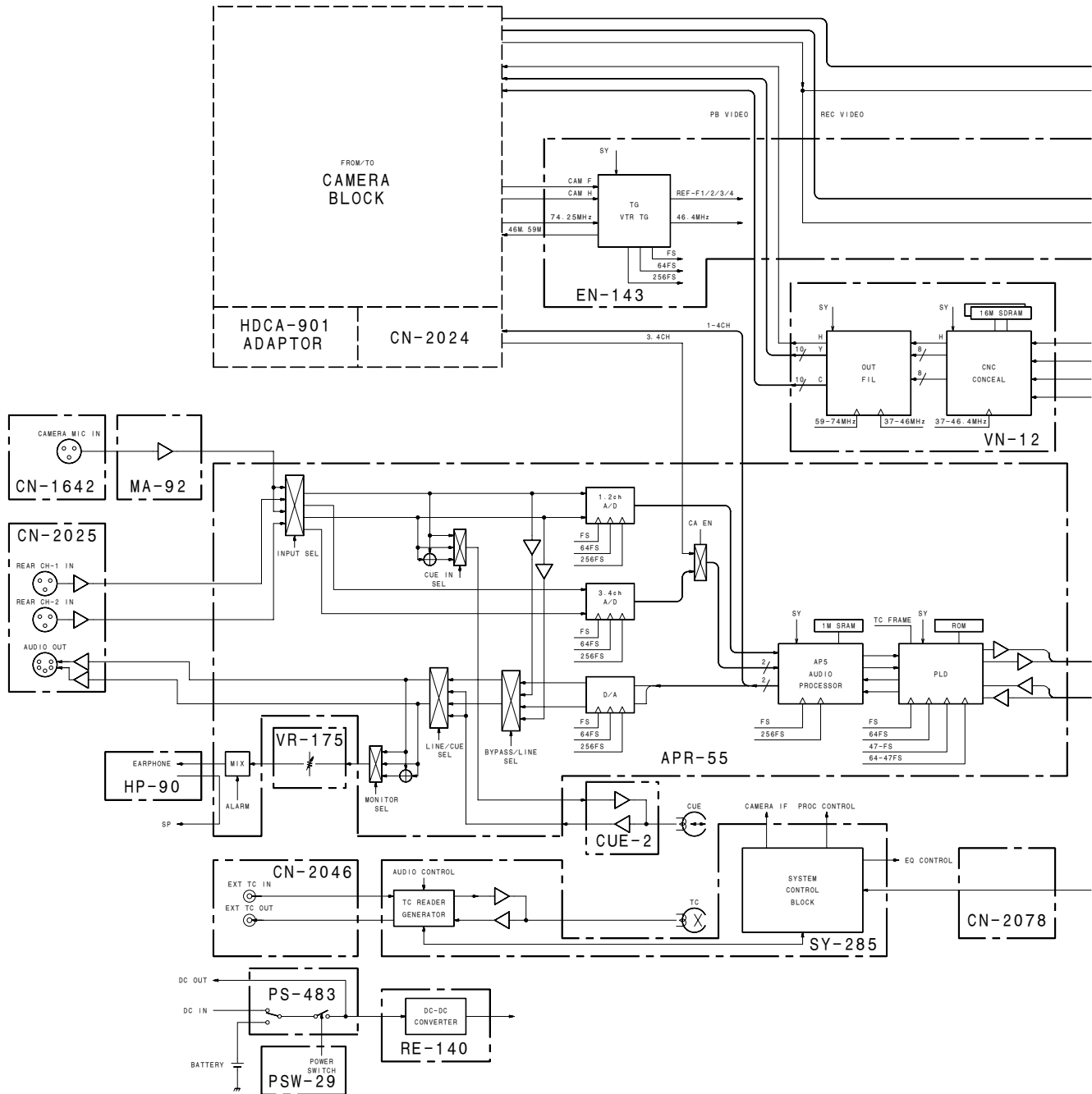

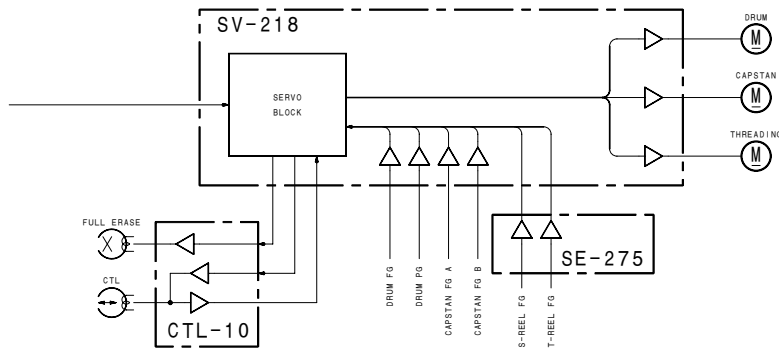
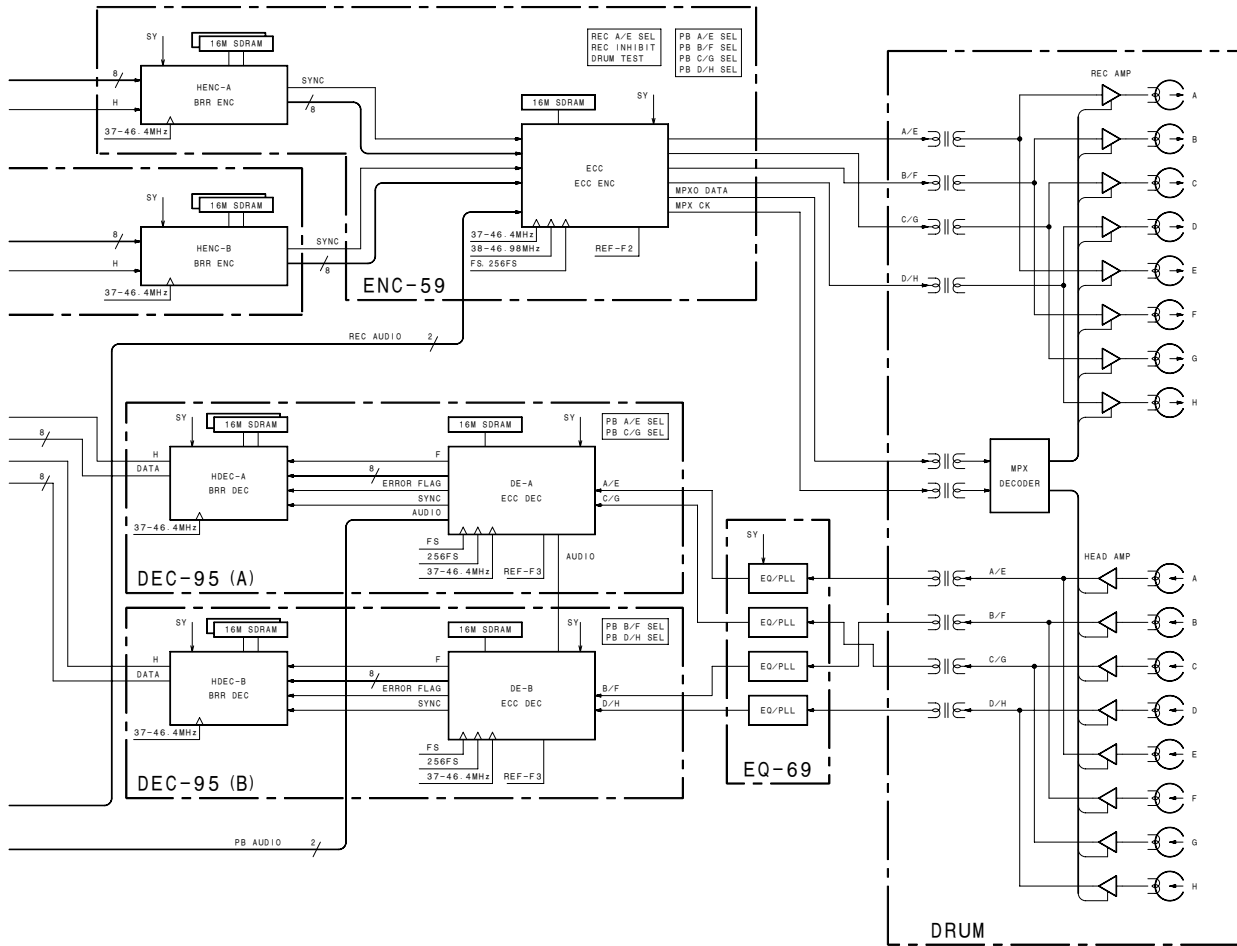

このマニュアルに記載されている事柄の著作権は当社にあります。

従って、当社の許可なしに無断で複写したり、説明内容(操作、保守等)と異なる目的で本マニュアルを使用することを禁止します。

The material contained in this manual consists of information that is the property of Sony Corporation. Sony Corporation expressly prohibits the duplication of any portion of this manual or the use thereof for any purpose other than the operation or maintenance of the equipment described in this manual without the express written permission of Sony Corporation.

Le matériel contenu dans ce manuel consiste en informations qui sont la propriété de Sony Corporation. Sony Corporation interdit formellement la copie de quelque partie que ce soit de ce manuel ou son emploi pour tout autre but que des opérations ou entretiens de l'équipement à moins d'une permission écrite de Sony Corporation.

Das in dieser Anleitung enthaltene Material besteht aus Informationen, die Eigentum der Sony Corporation sind. Die Sony Corporation untersagt ausdrücklich die Vervielfältigung jeglicher Teile dieser Anleitung oder den Gebrauch derselben für irgendeinen anderen Zweck als die Bedienung oder Wartung der in dieser Anleitung beschriebenen Ausrüstung ohne ausdrückliche schriftliche Erlaubnis der Sony Corporation.

